

One step ahead

Portable screw compressors



Reliable mobile compressed air solutions

C10-12 - C270TS-9

Designed To Last

CompAir Portable Compressors

Designed for the most demanding conditions.

High-precision construction projects demand that the efficiency and reliability of compressors is of the highest calibre. CompAir offers a wide range of portable compressors, with a reputation within the industry for just that – compressors that meet the requirements of numerous mobile compressed air applications.

The C-Series from CompAir is constantly evolving and guarantees high energy efficiency, low emissions and many other innovations, which make daily operations and maintenance tasks much easier.

Engineering Excellence

Changing emission legislation is a key driver for development, but CompAir's passionate engineering team also strive to achieve the best possible performance at the lowest operational costs. The C-Series of portable compressors fulfills the emission standards in accordance with the directive 97/68/EC. Additionally, the compressors are very compact and lightweight which is a preference for many customers.

The screw compression element is the most important component of the compressor. Therefore CompAir keeps the design and manufacture in-house, using the latest CNC rotor grinding machinery, coupled with online laser technology. The resulting reliability and performance ensures that operating costs will remain low throughout the life of the compressor.

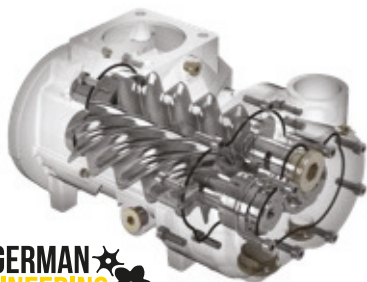

AirPlus

Tailored compressor solutions to fit your application.

CompAir offers numerous options and accessories allowing customers to configure the compressor according to the specific requirements of the application. Besides various components for air treatment, integrated generators, bundled bottom boxes, toolboxes, hose reels and integrated oilers, etc. can all be factory fitted.

To upgrade existing compressors according to current emission legislations, several models can be retrofitted with diesel particle filters (DPF). More information about AirPlus can be found on pages 14 and 15.

Compressed Air Tools

To complement our portable compressors, we offer a range of modern compressed air tools, which include various hammers, breakers, rockdrills and moles.



For further information please request our Compressed Air Tools brochure.



CompAir Genuine Parts

Enjoy complete peace of mind.

Genuine CompAir parts and lubricants ensure best performance and reliability is maintained.

- Minimum losses contributing to energy savings
- Long service life, even under harsh conditions
- High reliability



C10-12 to C14

1.0 to 1.4 m³ / min
Product range
DLT 0101



C10-12 to C14 is a powerful alternative to electrical tools. Small, compact and lightweight, at only 165kg weight with 1.0 to 1.4 m³ / min at 7 to 12 bar. Perfect for a wide-range of repair and installation jobs.

Electric Start as Standard

Easy to start and flexible operation.

Honda GX 630V

Air cooled petrol engine.

Technical Data - C10-12 to C14

Product Range	DLT 0101			
	C10-12	C12-10	C14	
Type				
Operational data				
Volume flow ¹⁾	m ³ / min	1.0	1.2	1.4
	cfm	35	42	49
Operating pressure	bar	12	10	7
	psi	174	145	101.5
Engine	Honda GX 630			
Installed engine power	kW	15.5	15.5	15.5
RPM-range	1 / min	2200 - 2900	2200 - 2900	2200 - 2900
Operating weight²⁾				
Portable compressor	kg	165	165	165
Filling capacities				
Engine oil	l	1.9	1.9	1.9
Fuel tank	l	20	20	20
Compressor oil	l	4.0	4.0	4.0
Dimensions and connections				
Length	mm	890	890	890
Width	mm	635	635	635
Height	mm	670	670	670
Compressed air outlets		1 x 3 / 4"		
Sound level				
Sound power level	SWL	93	93	93

¹⁾ Acc. to ISO 1217 Ed. 4 2009 Annex D ²⁾ Operating weight without options

C20 to C30

2.0 to 3.0 m³ / min
Product range
DLT 0206

This range has the output to run up to two breakers and is driven by quiet-running energy efficient Kubota engines. With the benefit of a wide engine speed range, fuel savings are increased and the engine reliability and lifetime are enhanced. The various applications of these compressors can be further enhanced by integrated generators, which can supply electric power for the site, lighting and electrical tools. With an operating weight of less than 500kg (unbraked) the compressor can be transported by small vehicles.

Soft Start

Extends the engine lifetime by reducing engine stress during start-up and allowing the engine to reach running temperature with the compressor unloaded.

Bolted Single Sheets

The steel canopy is galvanised and electrostatically coated, offering excellent protection against damage and corrosion. With bolted single sheets, exchange is both quick and easy.

Easy Access Hinged Hood

With two robust gas struts, the hood is light and easy to open, offering excellent accessibility for easy maintenance.

Kubota D1105/V1505

Reliable, energy efficient diesel engine.



Robust Plastic Protection

Protects the control panel and lighting elements.

Transparent Plastic Fuel Tank

Extremely robust, the plastic fuel tank allows direct visual level indication and contamination checks to be carried out in seconds.

Progressive Volume Flow Regulation

Engine speed and air intake regulation are automatically adapted to compressed air requirement.

Air End with Spin-on Oil Filter Cartridge

For quick and easy maintenance.

Internal Main Switch Board

To avoid unauthorised operation.

Central Lifting Eye

For easy handling by crane.

Operational Reliability

Designed for -10 to +45°C ambient temperature.

Oil Temperature Regulation Valve

Ensures safe operation of compressor at low ambient temperatures or extreme partial load as standard.

Portable-Control 1

- **Fully protected digital display**

With tamper proof hour counter

- **Automatic protection in case of malfunction:**

- Compressor temperature too high
- Engine oil pressure too low
- Engine temperature too high
- Battery voltage too low
- Fuel level too low

- **Indication lamps**

For automatic emergency stop in case of malfunction

- **Start by rotary switch**

To avoid loss of time caused by lost ignition key

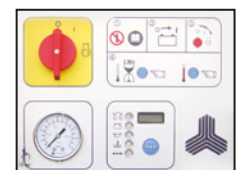

Technical Data - C20 to C30

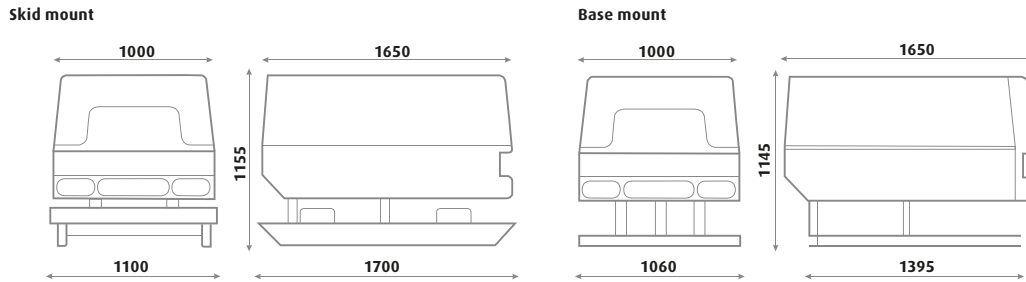
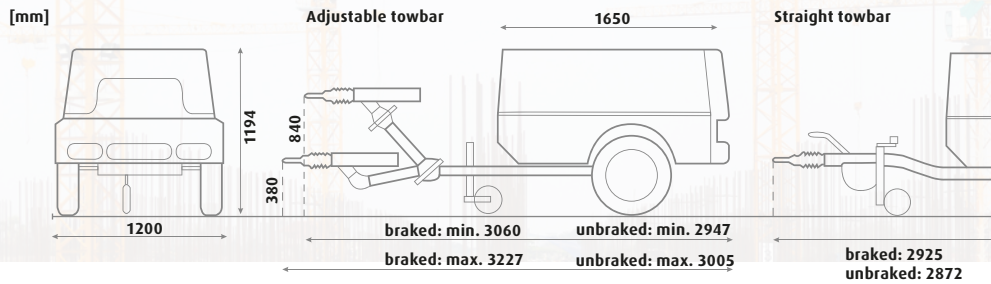

Product Range		DLT 0206						
Type		C20	C20GS	C20-14	C25	C25-10	C30	C30G
Operational data								
Volume flow ¹⁾	m ³ /min	2.0	2.0 ²⁾	2.0	2.5	2.5	3.0	3.0 ²⁾
	cfm	70.6	70.6	70.6	88	88	105.9	105.9
Operating pressure	bar	7	7	14	7	10	7	7
	psi	101.5	101.5	203	101.5	145	101.5	101.5
Engine		Kubota D1105	Kubota V1505		Kubota D1105	Kubota V1505		
Installed engine power	kW	16.3	23.1	23.1	19.4	23.1	23.1	23.1
RPM-range	1/min	2000 - 2600	1800 - 2600	1800 - 2600	2000 - 3000	1800 - 2600	1800 - 2600	1800 - 2600
Operating weight³⁾								
Portable compressor								
adjustable towbar braked	kg	580	658	611	586	610	610	658
adjustable towbar unbraked	kg	539	617	570	545	570	570	617
straight towbar braked	kg	558	636	588	564	588	588	636
straight towbar unbraked	kg	528	606	-	534	558	558	606
Base mount	kg	458	535	-	463	485	485	535
Skid mount	kg	498	575	-	503	525	525	575
Filling capacities								
Engine oil	l	5.1	6.0	6.0	5.1	6.0	6.0	6.0
Diesel tank	l	40	40	40	40	40	40	40
Compressor oil	l	6.3	6.6	6.6	6.6	6.6	6.6	6.6
Dimensions and connections								
Length	adjustable towbar braked	mm	3169-3227	3169-3227	3169-3227	3169-3227	3169-3227	3169-3227
	straight towbar braked	mm	2925	2925	2925	2925	2925	2925
Width	mm	1200	1200	1200	1200	1200	1200	1200
Height	mm	1194	1194	1194	1194	1194	1194	1194
Compressed air outlets		2 x 3/4"						
Sound level								
Sound pressure level ⁴⁾	dB(A) LPA	69	69	69	69	69	69	69

¹⁾ Acc. to ISO 1217 Ed. 4 2009 Annex D

²⁾ 9 kVA generator (C20GS max. 6 kVA)

³⁾ Operating weight without options

⁴⁾ Noise level acc. to PNEUROP PN8NTC2.2 at 7 m

C35-10 to C50

3.5 to 5.0 m³ / min

Product range

DLT 0408



The highly successful CompAir range C35-10 to C50 is driven by very quiet-running, water-cooled Yanmar 4-cylinder diesel engines. The compressor is particularly suitable for applications in cities and built-up areas, where stringent restrictions are set on noise emissions. The light construction of under 750 kg (C38 and C42 unbraked) makes the compressor suitable for many different applications and is therefore ideal for use by hire companies. These compact and lightweight compressors are available with various chassis and also with the option of integrated generator or aftercooler or both.

Soft Start

Extends the engine lifetime by reducing engine stress during start-up and allowing the engine to reach running temperature with the compressor unloaded.

Bolted Single Sheets

The steel canopy is galvanised and electrostatically coated, offering excellent protection against damage and corrosion. With bolted single sheets, exchange is both quick and easy.

Easy Access Hinged Hood

With two robust gas struts, the hood is light and easy to open, offering excellent accessibility for easy maintenance.

Yanmar 4TNV88BKCP

Quiet-running and low vibration 4-cylinder diesel engine with direct injection.

Robust Plastic Protection

Protects the control panel and lighting elements.

Fuel Filter

Fuel contamination is controlled by a high quality filter which includes water separation. In addition to this, every compressor has an electronic fuel pump, alarm and fuel cooler.

Air Filters

Separate air filters for engine and air compressor with lighting elements.

Progressive Volume Flow Regulation

Engine speed and air intake regulation are automatically adapted to compressed air requirement.

Air End with Spin-on Oil Filter Cartridge

For quick and easy maintenance.

Internal Main Switch Board

To avoid unauthorised operation.

Central Lifting Eye

For easy handling by crane.

Transparent Plastic Fuel Tank

Allows direct visual level indication and quick contamination checks.

Operational Reliability

Designed for -10 to +45°C ambient temperature.

Oil Temperature Regulation Valve

Ensures safe operation of compressor at low ambient temperatures or extreme partial load as standard.

Retrofit Kit For Diesel Particle Filter

For low emission zone compliance.

Optional Filtration

According to ZTV-ING part 3 section 4.



Portable-Control 2

- **Fully protected digital display**
With tamper proof hour counter
- **Indication lamps**
 - Preheat
 - Operation
 - Automatic emergency stop after malfunction
- **Start by rotary switch**
To avoid loss of time caused by lost ignition key
- **Automatic protection in case of malfunction:**
 - Compressor temperature too high
 - Engine oil pressure too low
 - Engine temperature too high
 - Battery voltage too low
 - Rotational speed too low
 - Cooling water too low
 - Fuel level too low

Technical Data - C35-10 to C50

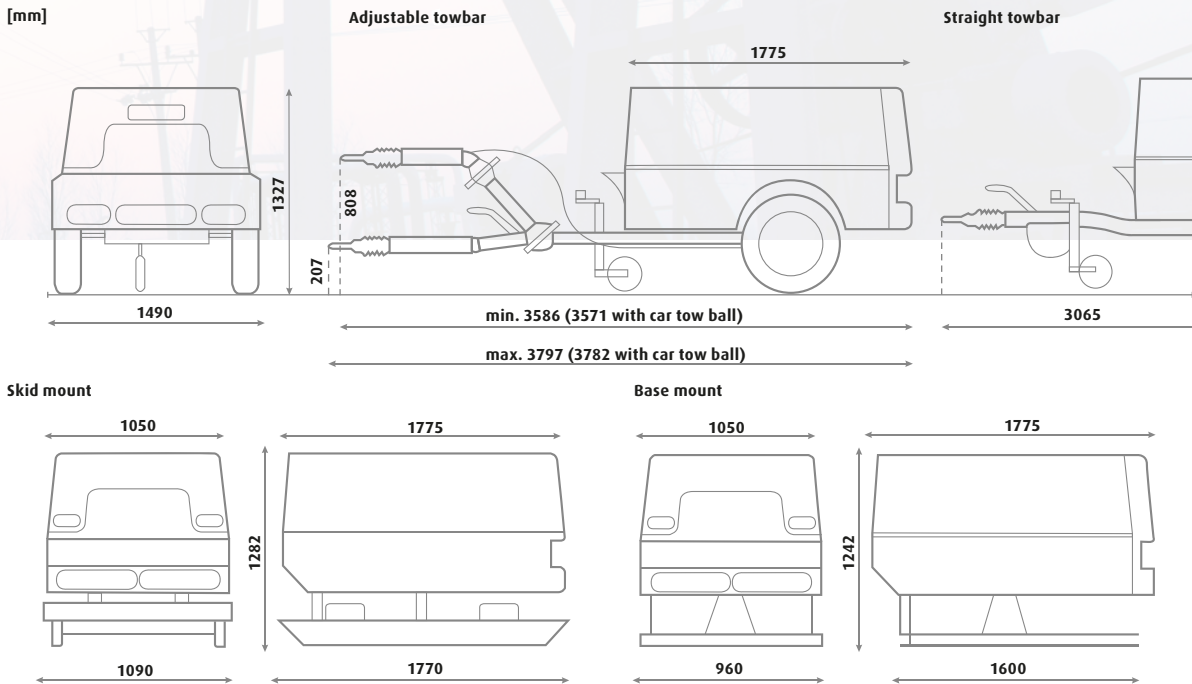

Product range		DLT 0408				
Type		C35-10	C38	C42	C50	
Operational data						
Volume flow ¹⁾	m ³ /min	3.5	3.8	4.2	5.0	
(Optional 9 or 15 kVA Generator)	cfm	123.6	134	148	176.5	
Operating pressure	bar	10	7	7	7	
	psi	145	101.5	101.5	101.5	
Engine		Yanmar 4TNV88BKCP				
Installed engine power	kW	35.0	35.0	35.0	35.0	
RPM-range	1/min	1600 - 2800	1600 - 2800	1600 - 2800	1600 - 2800	
Operating weight²⁾						
Portable compressor	adjustable towbar braked	kg	810	810	810	866
	adjustable towbar unbraked	kg	745	745	745	-
	straight towbar braked	kg	775	775	775	835
	straight towbar unbraked	kg	740	740	740	-
Base mount	kg	685	685	685	780	
Skid mount	kg	740	740	740	800	
Filling capacities						
Engine oil	l	7.4	7.4	7.4	7.4	
Diesel tank	l	60	60	60	60	
Compressor oil	l	9	9	9	9	
Dimensions and connections						
Length	adjustable towbar braked	mm	3586 - 3797	3586 - 3797	3586 - 3797	3586 - 3797
	straight towbar braked	mm	3065	3065	3065	3065
Width	mm	1490	1490	1490	1490	
Height (adjustable towbar, braked)	mm	1327	1327	1327	1327	
Compressed air outlet		2 x 3/4"				
Sound level						
Sound pressure level ³⁾	dB(A) LPA	69	69	69	69	

¹⁾ Acc. to ISO 1217 Ed. 4 2009 Annex D ²⁾ Operating weight without options ³⁾ Noise level acc. to PNEUROP PN8NTC.2.2 at 7 m

C55-14 to C76

5.5 to 7.6 m³ / min
Product range
DLT 0705

This new range of compressors stands out for its low diesel consumption, which is 10% less than the previous range. Equipped with a Diesel Particle Filter, these modern compressors are built to the latest emission standard Stage 3B. Thanks to a wide pressure range up to 14 bar, this compact compressor range is extremely versatile and meets the requirements of numerous applications. The compressors have enough storage capacity for two hammers, picks or any other pneumatic tools. Separate engine and compressor air filters guarantee a long service life. All of the service points are strategically located for easy access.

Soft Start

Extends the engine lifetime by reducing engine stress during start-up and allowing the engine to reach running temperature with the compressor unloaded.

Bolted Single Sheets

The steel canopy is galvanised and electrostatically coated, offering excellent protection against damage and corrosion. With bolted single sheets, exchange is both quick and easy.

Easy Access Hinged Hood

With two robust gas struts, the hood is light and easy to open, offering excellent accessibility for easy maintenance.

Yanmar 4TNV98CT-NCP

Quiet-running and low vibration 4-cylinder diesel engine with diesel particle filter.

Robust Plastic Protection

Protects the control panel and lighting elements.



Fuel Filter

Fuel contamination is controlled by a high quality filter which includes water separation. In addition to this every compressor has an electronic fuel pump.

Air Filters

Separate air filters for engine and air compressor with lighting elements.

Progressive Volume Flow Regulation

Engine speed and air intake regulation are automatically adapted to compressed air requirement.

Air End With Spin-On Oil Filter Cartridge

For quick and easy maintenance.

Internal Main Switch Board

To avoid unauthorised operation.

Central Lifting Eye

For easy handling by crane.

Transparent Plastic Fuel Tank

Allows direct visual level indication and quick contamination checks, includes drain port.

Operational Reliability

Designed for -10 to +45°C ambient temperature.

Oil Temperature Regulation Valve

Ensures safe operation of compressor at low ambient temperatures or extreme partial load as standard.

Optional Filtration

According to ZTV-ING part 3 section 4.

Portable-Control 2+

- **Fully protected digital display**

With tamper proof hour counter

- **Indication lamps**

For automatic emergency stop in case of malfunction

- **Automatic protection in case of malfunction:**

- Compressor temperature too high

- Engine oil pressure too low
- Engine temperature too high
- Battery voltage too low
- Fuel level too low
- Service requirement Diesel Particle Filter



Technical Data - C55-14 to C76

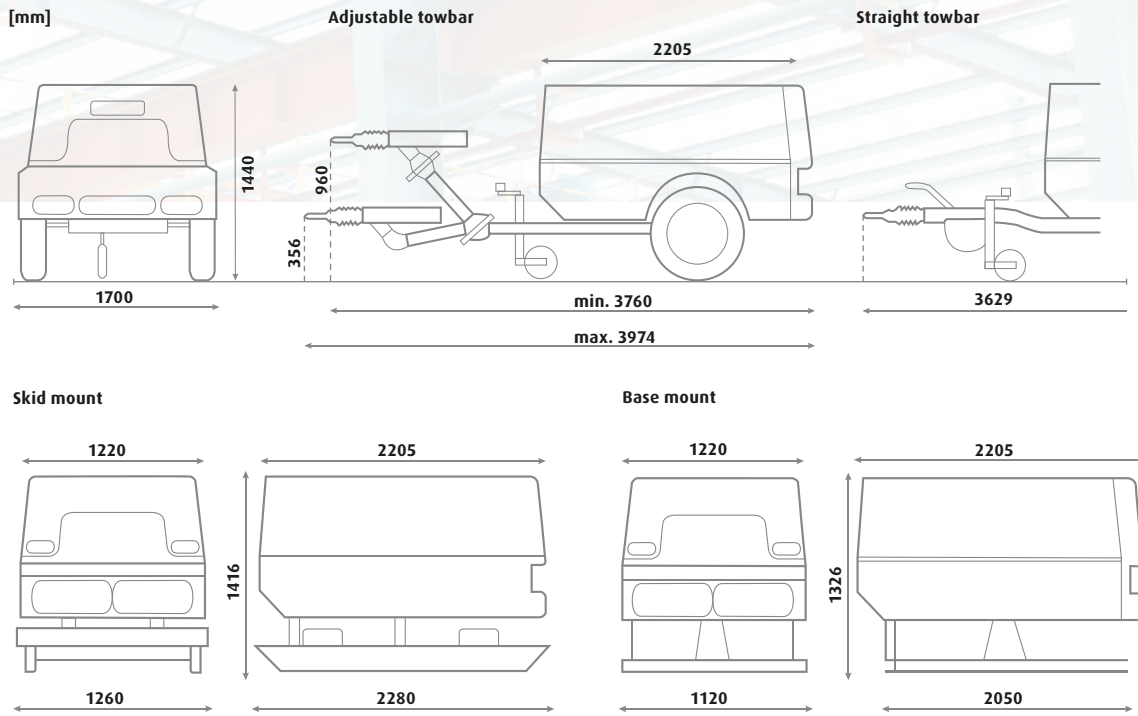

Product range		DLT 0705				
Type		C55-14	C60-12	C65-10	C65HS	C76
Operational data						
Volume flow ¹⁾	m ³ /min	5.5	6.0	6.5	6.5	7.6
(Optional 9 or 15 kVA Generator)	cfm	194	211.9	229.5	229.5	268
Operating pressure	bar	14	12	10	7	7
	psi	203	174	145	101.5	101.5
Engine		Yanmar 4TNV98CT-NCP, 4-cylinder, water-cooled				
Installed engine power	kW	53.7	53.7	53.7	53.7	53.7
RPM range	1/min	1500 - 2500	1500 - 2500	1500 - 2500	1500 - 2500	1500 - 2500
Operating weight ²⁾						
Portable compressor	adjustable towbar braked	kg	1240	1240	1240	1240
	straight towbar braked	kg	1200	1200	1200	1200
Base mount		kg	1100	1100	1100	1100
Skid mount		kg	1150	1150	1150	1150
Filling capacities						
Engine oil	l	8	8	8	8	8
Diesel tank	l	140	140	140	140	140
Compressor oil	l	17.5	17.5	17.5	17.5	17.5
Dimensions and connections						
Length	adjustable towbar braked	mm	3760-3974	3760-3974	3760-3974	3760-3974
	straight towbar braked	mm	3629	3629	3629	3629
Width		mm	1700	1700	1700	1700
Height		mm	1440	1440	1440	1440
Compressed air outlet			3 x 3/4", optionally 1 x 1/2"			
Sound level						
Sound pressure level ³⁾	dB(A) LPA		71	71	71	71

¹⁾ Acc. to ISO 1217 Ed. 4 2009 Annex D

²⁾ Operating weight without options

³⁾ Noise level acc. to PNEURO PN8NTC.2.2 at 7 m

C85-14 to C140-9

8.6 to 13.3 m³ / min
Product range
DLT 1304

Designed for the toughest site conditions, whether it's for road building, civil engineering or restoration work, this range of compressors offers outstanding reliability, performance and compressed air quality. With fully accessible doors, maintenance is also made easy. The compressor as standard is equipped with numerous options, offering a substantial cost saving to the customer. Thanks to the inclusion of two batteries, reliable running and performance can be achieved even in cold conditions. The long life cycle of these compressors is further enhanced by additional engine management protection. Energy efficient Deutz TCD4.1 L4 Diesel engines are fitted with electronic fuel injection to meet the European exhaust emission standards.

Soft Start

Extends the engine lifetime by reducing engine stress during start-up and allowing the engine to reach running temperature with the compressor unloaded.

Easy Access Side Wing Doors

Offering excellent accessibility for easy maintenance.

Air Filters

Separate air filters for engine and air compressor.

Reliable, Robust and Diesel-saving DEUTZ TCD4.1 L4 Series Engine

- Fulfills stage IV of the EU emission standard and is ready to fulfil the pending EU emission standard stage V (from 2019).
- Diesel Particle Filter (DPF) as standard.

Robust Plastic Protection

Protects the control panel and lighting elements.



Fuel Filter

Fuel contamination is controlled by a high quality filter which includes water separation. In addition to this every compressor has a manual fuel pump as standard.

24 V Electric System

Ensures sufficient power reserves in case of cold starts and a safe run-up ability.

Progressive Volume Flow Regulation

Engine speed and air intake regulation are automatically adapted to compressed air requirement.

Air End With Spin-On Oil Filter Cartridge

For quick and easy maintenance.

Internal Main Switch Board

To avoid unauthorised operation.

Central Lifting Eye

For easy handling by crane.

Plastic Fuel Tank

With direct visual level indication.

Operational Reliability

Designed for -10 to +45°C ambient temperature.

Oil Temperature Regulation Valve

Ensures safe operation of compressor at low ambient temperatures or extreme partial load.

Optional Filtration

According to ZTV-ING part 3 section 4.

Portable-Control 3

• Digital display

All the necessary operation data at a glance

• Quick and easy pressure setting

• Fault memory with detailed operating data

• Automatic protection in case of malfunction:

- Engine oil pressure too low
- Cooling water temperature too high

- Intercooler temperature too high
- Airend temperature too high
- Engine Cooling water level too low
- Fuel level too low
- Water in fuel pre filter
- Load control (v-belt break, alternator defect)
- Hardware errors



Technical Data - c85-14 to C140-9

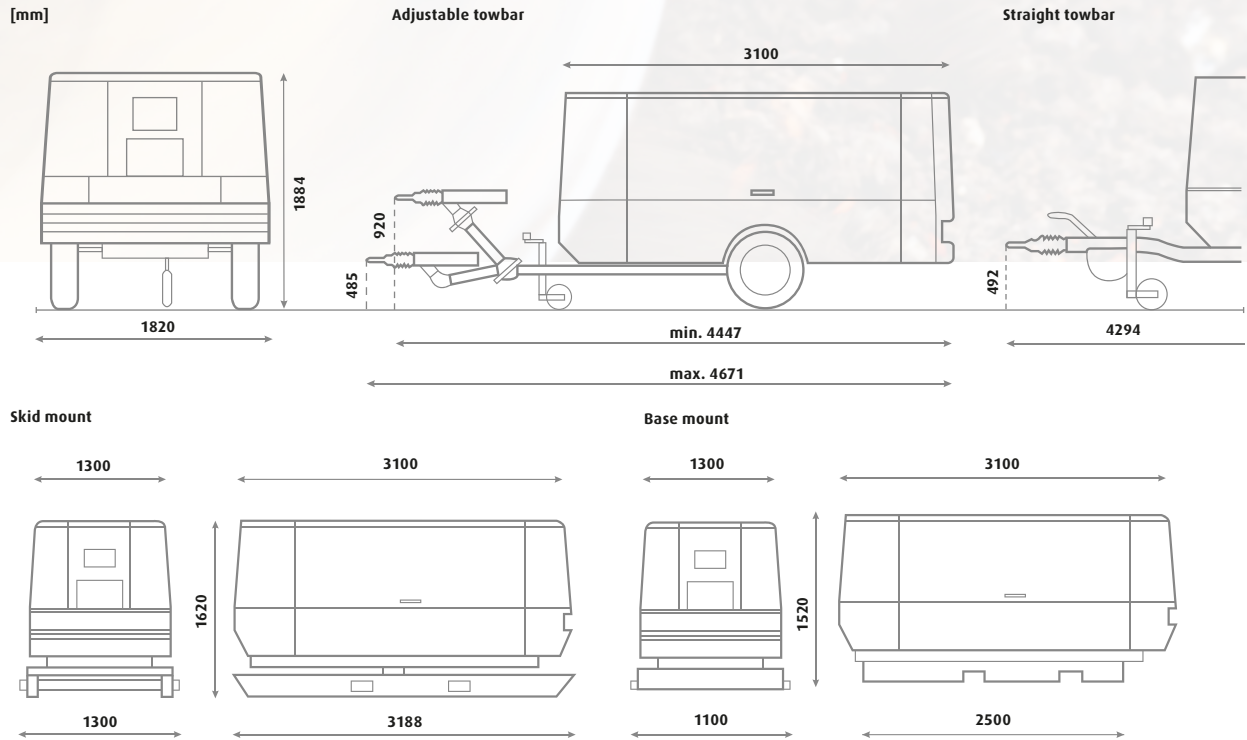

Product range		DLT 1304							
Type		C85-14	C95-12	C100-10	C110-9	C105-14	C115-12	C130-10	C140-9
Operational data									
Volume flow ¹⁾	m ³ /min	8.6	9.4	10.0	10.8	10.5	11.5	12.5	13.3
	cfm	304	332	353	381	371	406	441	470
Operating pressure range	bar	5-14	5-12	5-10	5-8.6	5-14	5-12	5-10	5-8.6
	psi	73-203	73-174	73-145	73-125	73-203	73-174	73-145	73-125
Engine		Deutz TCD 4.1 L4							
Installed engine power	kW	90	90	90	90	105	105	105	105
RPM-range	1/min	1300 - 1850	1300 - 2000	1300 - 2100	1300 - 2300	1300 - 1750	1300 - 1900	1300 - 2050	1300 - 2200
Operating weight ²⁾									
Portable compressor									
	adjustable towbar braked	kg	2075	2075	2075	2075	2160	2160	2160
	straight towbar braked	kg	2000	2000	2000	2000	2085	2085	2085
Base mount		kg	1860	1860	1860	1860	1945	1945	1945
Skid mount		kg	1970	1970	1970	1970	2055	2055	2055
Filling capacities									
Engine oil	l	11.5	11.5	11.5	11.5	11.5	11.5	11.5	11.5
Diesel tank	l	175	175	175	175	175	175	175	175
Adblue tank capacity	l	20	20	20	20	20	20	20	20
Compressor oil	l	20	20	20	20	25.5	25.5	25.5	25.5
Dimensions and connections									
Length	adjustable towbar braked	mm	4447-4671	4447-4671	4447-4671	4447-4671	4447-4671	4447-4671	4447-4671
	straight towbar braked	mm	4294	4294	4294	4294	4294	4294	4294
Width	mm	1820	1820	1820	1820	1820	1820	1820	1820
Height	mm	1884	1884	1884	1884	1884	1884	1884	1884
Compressed air outlet	2 x 3/4" and 1 x 2"								
Sound level									
Sound pressure level ³⁾	dB(A) LPA	70	70	70	70	70	70	70	70

¹⁾ Acc. to ISO 1217 Ed. 4 2009 Annex D

²⁾ Operating weight without options

³⁾ Noise level acc. to PNEUROPN8NTC2.2 at 7 m

C200TS-24 to C270TS-9

20 to 27.0 m³/min
Product range
DLT 2702



The TurboScrew compressors with their unique patented bi-turbo technology provide class-leading diesel efficiency, the lowest weight of 3,500kg and super-clean performance in accordance with directive 97/68/EC Stage 4 final. The new range has been equipped with an award winning SCRT® – Selective Catalytic Reduction Technology system which is capable of removing almost all nitrogen oxide emissions from diesel exhaust gases.



TURBOSCREW

TurboScrew Technology

CompAir's TurboScrew compression system is a radical new approach to energy conservation. It uses a Cummins turbo assisted engine powering a CompAir screw compressor unit with the addition of an engine exhaust gas drive turbine, pre-compressing the suction inlet air before it enters the compression chamber.

Soft Start

Extends the engine lifetime by reducing engine stress during start-up and allowing the engine to reach running temperature with the compressor unloaded.

Easy Access Side Wing Doors

Offering excellent accessibility for easy maintenance.

SCRT® System

Simultaneous reduction of soot particles and nitrogen oxides.

Cummins QSB 6.7

Robust 6-cylinder turbo-charged diesel engine with an additionally integrated second turbo-charger for the pre-compression of the inlet air of the compressor.

24 V Electric System

Ensures sufficient power reserves in case of cold starts and a safe run-up ability.

Bolted Single Sheets

The steel canopy is galvanised and electrostatically coated, offering excellent protection against damage and corrosion. With bolted single sheets, exchange is both quick and easy.

Small footprint & one of the lightest in class

The lightweight TurboScrew compressors can be towed by a vehicle with a maximum towing weight of 3,500kg and is great for getting to hard-to-access sites.

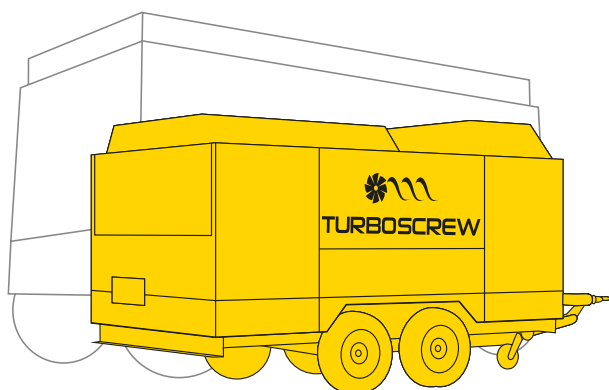

Potential fuel savings

Based on average site running conditions, over lifetime of 10,000 hours, fuel savings of up to 30% can be achieved when compared with equivalent conventional compressors of this output range. This represents up to 20% of total lifetime costs.

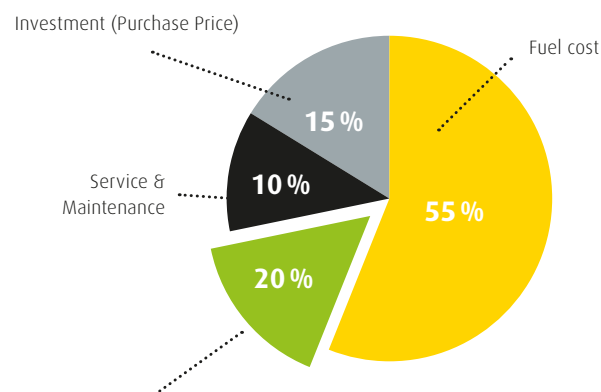

TurboScrew fuel savings = 20% of lifetime cost

Technical Data - C200TS-24 to C270TS-9

[mm]

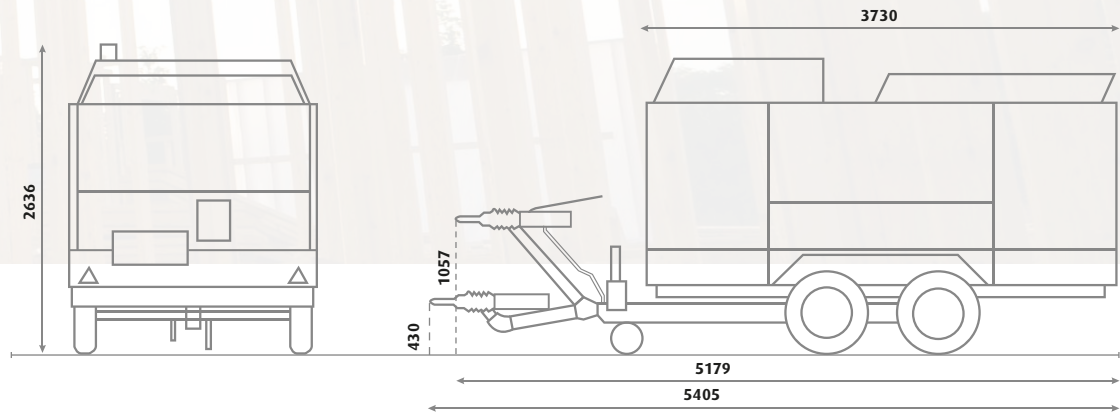

Skid mount

Base mount

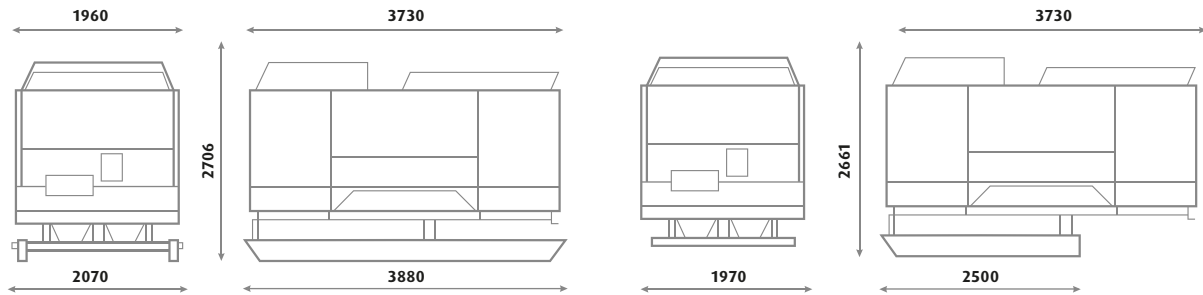

Product range	DLT 2702									DLT 2702 HP		
Type	C200TS-14	C210TS-12	C220TS-10	C230TS-9	C240TS-14	C250TS-12	C260TS-10	C270TS-9	C200TS-24	C210TS-21	C230TS-17	
Operational data												
Volume flow ¹⁾	m ³ /min	20	21	22	23	24	25	26	27	20	21	23
	cfm	706	741.6	776.9	812	847.5	882.8	918	953	706	741.6	812
Operating pressure	bar	14	12	10	9	14	12	10	9	24	21	17
	psi	203	174	145	130.5	203	174	145	130.5	348	304.5	246.5
Engine	Cummins QSB 6.7									Cummins QSB 6.7		
Installed engine power	kW	180	180	180	180	224	224	224	224	224	224	224
Engine off load speed	1/min	1200	1200	1200	1200	1200	1200	1200	1200	1200	1200	1200
Engine full load speed	1/min	2400	2400	2400	2400	2400	2400	2400	2400	2400	2400	2400
Operating weight²⁾												
Portable compressor												
adjustable towbar braked	kg	3450	3450	3450	3450	3490	3490	3490	3490	3490	3490	3490
Skid mount	kg	3545	3545	3545	3545	3585	3585	3585	3585	3585	3585	3585
Base mount	kg	3385	3385	3385	3385	3425	3425	3425	3425	3425	3425	3425
Filling capacities												
Engine oil	l	17	17	17	17	17	17	17	17	17	17	17
Diesel tank	l	350	350	350	350	350	350	350	350	350	350	350
Adblue tank capacity	l	38	38	38	38	38	38	38	38	38	38	38
Compressor oil	l	65	65	65	65	70	70	70	70	55	55	55
Dimensions and connections												
Length	mm	5179-5405	5179-5405	5179-5405	5179-5405	5179-5405	5179-5405	5179-5405	5179-5405	5179-5405	5179-5405	5179-5405
Width	mm	1960	1960	1960	1960	1960	1960	1960	1960	1960	1960	1960
Height	mm	2568	2568	2568	2568	2568	2568	2568	2568	2568	2568	2568
Compressed air outlet		3 x 3/4" and 1 x 2"									1 x 2"	
Sound level												
Sound pressure level ³⁾	dB(A) LPA	71	71	71	71	71	71	71	71	71	71	71

¹⁾ Acc. to ISO 1217 Ed. 4 2009 Annex D

²⁾ Operating weight without options

³⁾ Noise level acc. to PNEUROP PN8NTC.2.2 at 7 m

AirPlus - Many Options for Many Applications

Options for all types of C10-12 to C270TS-9



Breakers



Sand-blasting

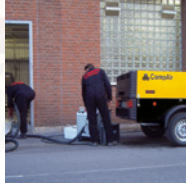

Ice-blasting



Drillings



Concrete spraying

AirPlus Options

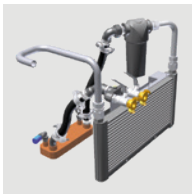

Built-in aftercooler

With automatic water separation. Reduces water content in the compressed air. An additional heat exchanger uses compressor oil to heat the compressed air which protects the tools from freezing.



Integrated Oiler

For optimised lubrication of the pneumatic tools.

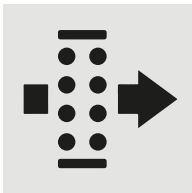

Built-in microfilter combination

(in addition to above mentioned aftercooler)
Air treatment with microfilters according to ISO 8573.1 standards including ZTV-ING 90 with residual oil content of <math><0.01\text{ ppm}</math>.



Hose reel

With 20m light self-supporting hose; protects the air hose and enables fast set up of tools at site.



Oil temperature regulation valve

Ensures safe operation of compressor at low ambient temperatures. Prevents compressed air tools from freezing. Standard from C35-10.



Special paint colour and labelling to customer specification

Provides distinctive site identity and assists in traceability in the event of loss or theft.

Schematic display of all available air treatment options

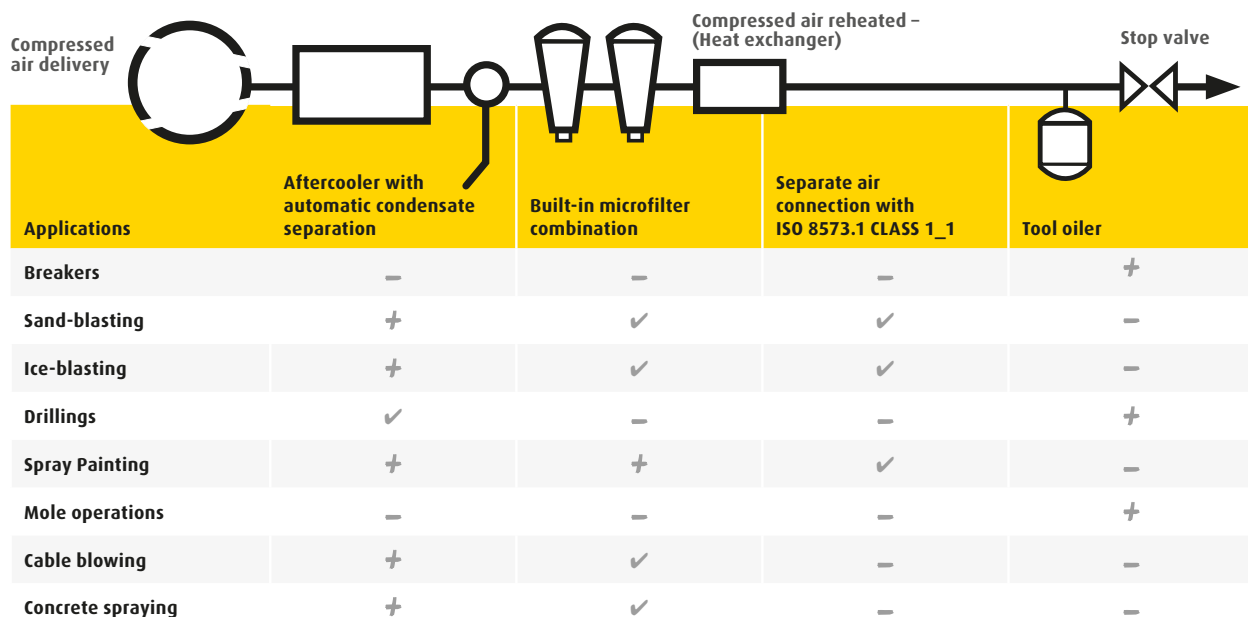

+ recommended ✓ depending on manufacturer and application - not needed

AirPlus - Many Options for Many Applications

Options for all types of C14 to C270TS-9

+ Optional ✓ Standard - Not available

Type	Compressed Air Quality			Compressor Equipment							Integrated Generator				Engine Accessories		
	Aftercooler	Filtration	Oiler	Tool-Box	Hose reel	Bundled bottom box	Oil thermostatic valve	Remote start / stop	Diesel Particle Filter Factory Fitted	Diesel Particle Filter Retrofit Kit	7 kVA at 110V 50Hz	9 kVA / 16 A max. at 230 / 400V 50Hz	15 kVA / 20 A max. at 230 / 400V 50 Hz	Diesel filter with water separator	Spark arrester	Engine shutdown from flammable gases	
DLT 0101																	
C10-12	+	-	+	-	-	-	-	-	-	-	-	-	-	-	-	-	
C12-10	+	-	+	-	-	-	-	-	-	-	-	-	-	-	-	-	
C14	+	-	+	-	-	-	-	-	-	-	-	-	-	-	-	-	
DLT 0206																	
C20	+	-	+	+	+	+	+	-	-	-	+	+	-	✓	+	+	
C20-14	+	-	+	+	+	+	+	-	-	-	+	+	-	✓	+	+	
C25	+	-	+	+	+	+	+	-	-	-	-	-	-	✓	+	+	
C25-10	+	-	+	+	+	+	+	-	-	-	-	-	-	✓	+	+	
C30	+	-	+	+	+	+	+	-	-	-	+	+	-	✓	+	+	
DLT 0408																	
C35-10	+	+	+	+	+	+	✓	-	+	+	+	+	+	✓	+	+	
C38	+	+	+	+	+	+	✓	-	+	+	+	+	+	✓	+	+	
C42	+	+	+	+	+	+	✓	-	+	+	+	+	+	✓	+	+	
C50	+	+	+	+	+	+	✓	-	+	+	+	+	+	✓	+	+	
DLT 0705																	
C55-14	+	+	+	+	+	+	✓	+	✓	-	+	+	+	✓	-	+	
C60-12	+	+	+	+	+	+	✓	+	✓	-	+	+	+	✓	-	+	
C65-10	+	+	+	+	+	+	✓	+	✓	-	+	+	+	✓	-	+	
C76	+	+	+	+	+	+	✓	+	✓	-	+	+	+	✓	-	+	
DLT 1304																	
C85-14	+	+	+	-	-	-	✓	+	✓	-	+	+	+	✓	-	-	
C95-12	+	+	+	-	-	-	✓	+	✓	-	+	+	+	✓	-	-	
C100-10	+	+	+	-	-	-	✓	+	✓	-	+	+	+	✓	-	-	
C110-9	+	+	+	-	-	-	✓	+	✓	-	+	+	+	✓	-	-	
C105-14	+	+	+	-	-	-	✓	+	✓	-	+	+	+	✓	-	-	
C115-12	+	+	+	-	-	-	✓	+	✓	-	+	+	+	✓	-	-	
C130-10	+	+	+	-	-	-	✓	+	✓	-	+	+	+	✓	-	-	
C140-9	+	+	+	-	-	-	✓	+	✓	-	+	+	+	✓	-	-	
DLT 2702																	
C200TS-14	+	+	-	-	-	-	✓	+	✓	-	-	-	-	✓	-	-	
C210TS-12	+	+	-	-	-	-	✓	+	✓	-	-	-	-	✓	-	-	
C220TS-10	+	+	-	-	-	-	✓	+	✓	-	-	-	-	✓	-	-	
C230TS-9	+	+	-	-	-	-	✓	+	✓	-	-	-	-	✓	-	-	
C240TS-14	+	+	-	-	-	-	✓	+	✓	-	-	-	-	✓	-	-	
C250TS-12	+	+	-	-	-	-	✓	+	✓	-	-	-	-	✓	-	-	
C260TS-10	+	+	-	-	-	-	✓	+	✓	-	-	-	-	✓	-	-	
C270TS-9	+	+	-	-	-	-	✓	+	✓	-	-	-	-	✓	-	-	
C200TS-24	-	-	-	-	-	-	✓	+	✓	-	-	-	-	✓	-	-	
C210TS-21	-	-	-	-	-	-	✓	+	✓	-	-	-	-	✓	-	-	
C230TS-17	-	-	-	-	-	-	✓	+	✓	-	-	-	-	✓	-	-	

- Integrated Generator**

- Electronically controlled synchronous generator
- Protection IP 54

- Winter Kit**

- Available for selected models



Global experience - truly local service

With over 200 years of engineering excellence, the CompAir brand offers an extensive range of highly reliable, energy efficient compressors and accessories to suit all applications. An extensive network of dedicated CompAir sales companies and distributors across all continents provide global expertise with a truly local service, ensuring our advanced technology is backed up with the right support.



As part of the worldwide Gardner Denver operation, CompAir has consistently been at the forefront of compressed air systems development, culminating in some of the most energy efficient and low environmental impact compressors on the market today, helping customers achieve or surpass their sustainability targets.

Portable Compressors (EU & Non EU Range)

C10-12 - C270TS-9

1 to 27 m³/min from 7 to 24 bar

Air Plus offers many variations and options:

- Aftercooler
- Ultra-fine filters
- Integrated generator
- Bunded bottom box
- Hose reel
- Exhaust spark arrestor
- Exhaust gas particulate filter
- Customer colours

Tools

- Chipping Hammers
- Rockdrills
- Pickhammers
- Breakers

Vibration damped tools:

- Rockdrills
- Pickhammers
- Breakers

Accessories:

- Large selection of pointed chisel, slat chisel and spade
- In line lubricator
- Water separator with or without oiler
- Air hoses

Services

- Technical support and advice
- Worldwide service network
- Reliable supply of spare parts
- Individual customer solutions
- Seminars and trainings

**2 YEAR
GUARANTEE**

s@compair.com