

OPERATOR'S SAFETY AND SERVICE MANUAL

F36/4 F46/4

This manual covers the following serial numbers and higher,
for each model listed:

F36/4..... 3630001.
F46/4..... 4630001.



WALK-BEHIND TROWELS

TABLE OF CONTENTS

Safety Information	1	Changing Trowel Blades	8
Introduction	1	Setting Tilt Arm Carriage Bolt Height	8
Safety Precautions	1	Service	9
Safety Decals	1	Torque Chart	9
Safety Decals - Constant Force Pitch Handle	3	Service Tools	9
Specifications	4	Gearbox Disassembly	9
Operation	5	Gearbox Assembly	9
Introduction	5	CFP Handle Cable/Spring Replacement	10
Before Starting & Operating	5	Standard Handle Pitch Cable Replacement	11
Starting Engine	5	Spider Bushing Replacement	12
Operating	5	Parts Replacement Cycles and Tolerances	12
Blade Pitch Adjustment (Standard)	5	Replacement Parts	13
Blade Pitch Adjustment (Constant Force)	5	Gearbox Assembly	14
Handle Bar Adjustment	5	15
Stopping Engine	6	Spider Assembly	16
.....	17
Maintenance	7	Drive Assembly	18
Maintenance Schedule	7	19
Fluid Levels	7	Guard Assembly	20
Engine Maintenance	7	21
Engine Oil	7	Handle Assembly	22
Engine Speed	7	23
Cleaning	7	Constant Force Handle Assembly	24
Lubrication	7	25
Lifting	8	Warranty	26
Storage	8		



WARNING



CALIFORNIA PROPOSITION 65 WARNING

Engine exhaust and some of its constituents are known in the state of California to cause cancer, birth defects, and other reproductive harm.

SAFETY INFORMATION

Introduction



This Safety Alert Symbol is used to call attention to items or operations which may be dangerous to those operating or working with this equipment. The symbol can be found throughout this manual and on the unit. Please read these warnings and cautions, along with all decals, carefully before attempting to operate the unit. Make sure every individual who operates or works with this equipment is familiar with all safety precautions.

WARNING

GENERAL WARNING. Indicates information important to the proper operation of the equipment. Failure to observe may result in damage to the equipment and/or severe bodily injury or death.

CAUTION

GENERAL CAUTION. Indicates information important to the proper operation of the equipment. Failure to observe may result in damage to the equipment.

Safety Precautions



LETHAL EXHAUST GAS: An internal combustion engine discharges carbon monoxide, a poisonous, odorless, invisible gas. Death or serious illness may result if inhaled. Operate only in an area with proper ventilation. NEVER OPERATE IN A CONFINED AREA!



DANGEROUS FUELS: Use extreme caution when storing, handling and using fuels, as they are highly volatile and explosive in vapor state. Do not add fuel while engine is running. Stop and cool the engine before adding fuel. DO NOT SMOKE!



SAFETY GUARDS: It is the owner's responsibility to ensure that all guards and shields are in place and in working order.



IGNITION SYSTEMS: Breakerless, magneto, and battery ignition systems can cause severe electrical shocks. Avoid contacting these units or their wiring.



SAFE DRESS: Do not wear loose clothing, rings, wristwatches, etc. near machinery.



NOISE PROTECTION: Wear OSHA specified hearing protection devices.



EYE PROTECTION: Wear OSHA specified eye shields, safety glasses, and sweat bands.



FOOT PROTECTION: Wear OSHA specified steel-tipped safety shoes.



HEAD PROTECTION: Wear OSHA specified safety helmets.



DUST PROTECTION: Wear OSHA specified dust mask or respirator.

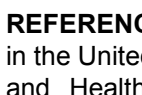

OPERATOR: Keep children and bystanders off and away from the equipment.

REFERENCES: For details on safety rules and regulations in the United States, contact your local Occupational Safety and Health Administration (OSHA) office. Equipment operated in other countries must be operated and serviced in accordance and compliance with any and all safety requirements of that country. The publication of these safety precautions is done for your information. MBW does not by the publication of these precautions, imply or in any way represent that these are the sum of all dangers present near MBW equipment. If you are operating MBW equipment, it is your responsibility to insure that such operation is in full accordance with all applicable safety requirements and codes. All requirements of the United States Federal Occupational Safety and Health Administration Act must be met when operated in areas that are under the jurisdiction of that United States Department.

Safety Decals

Carefully read and follow all safety decals. Keep them in good condition. If decals become damaged, replace as required. If repainting the unit, replace all decals. Decals are available from authorized MBW distributors. Order the decal set listed on the following page(s).

RUN ← IDLE

 ⚠ WARNING

 Start engine at idle only!
 NEVER place foot on guard ring.

12265

19961

⚠ WARNING

 Correct starting position!

12267

F36/4
POWER TROWEL

19962 - 36"

19963 - 46"

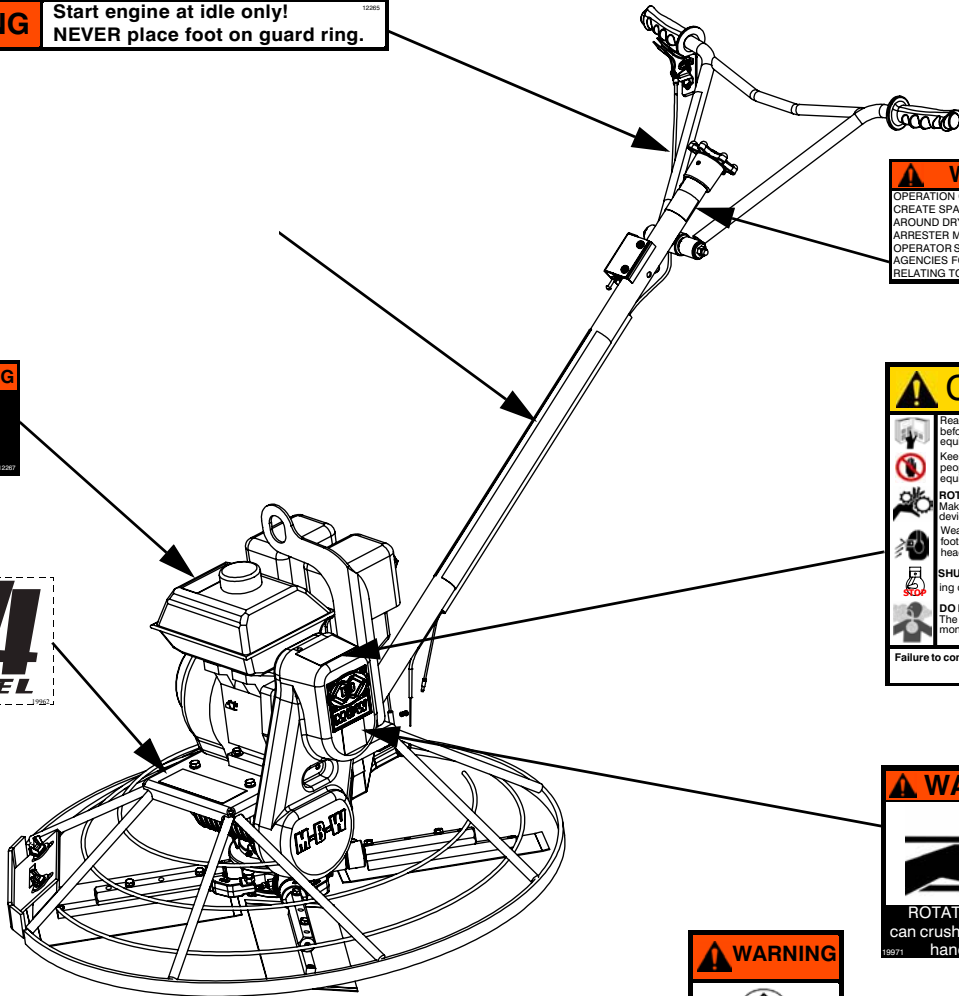

⚠ WARNING ⚠

OPERATION OF THIS EQUIPMENT MAY CREATE SPARKS THAT CAN START FIRES AROUND DRY VEGETATION. A SPARK ARRESTER MAY BE REQUIRED. THE OPERATOR SHOULD CONTACT LOCAL FIRE AGENCIES FOR LAWS OR REGULATIONS RELATING TO FIRE PREVENTION.

19791

⚠ CAUTION

Read the Operating Instructions before operating this piece of equipment.
 Keep unauthorized and untrained people away from this equipment.
ROTATING & MOVING PARTS! Make sure all guards and safety devices are in place.
 Wear approved hearing protection, foot protection, eye protection and head protection.
SHUT OFF the motor before servicing or cleaning.
DO NOT RUN in an enclosed area. The engine produces carbon monoxide, a **POISONOUS GAS**.

Failure to comply could result in serious bodily injury.

13483

⚠ WARNING

ROTATING PARTS can crush and cut. Keep hands away!

19971

⚠ WARNING

When lifting attach proper safety chains to hook.
 Approximate weight
 F46 Models:
 300 lbs. (136 kg)
 F36 Models:
 200 lbs. (91 kg)

01449

M-B-W INC.
P.O. Box 440, Sheboygan, WI 53089
 USA * ENGLAND

SAFETY SWITCH

ON

 OFF

01260

OPERATING INSTRUCTIONS

1. Check engine oil and trowel gearbox oil.
2. Open fuel valve, put engine switch on.
3. Put **SAFETY SWITCH** in ON position; set throttle to idle position.
4. Choke engine. A warm engine may not need to be choked.
5. Starting engine: Place one hand on trowel handle and other hand on engine starter rope. NEVER place foot on guard ring. Pull starter rope.
6. Open choke, allow engine to warm up at idle.
7. Position throttle for various operating conditions.
8. TO STOP: Return throttle to idle position, put safety switch to off position. Close fuel valve.

19970

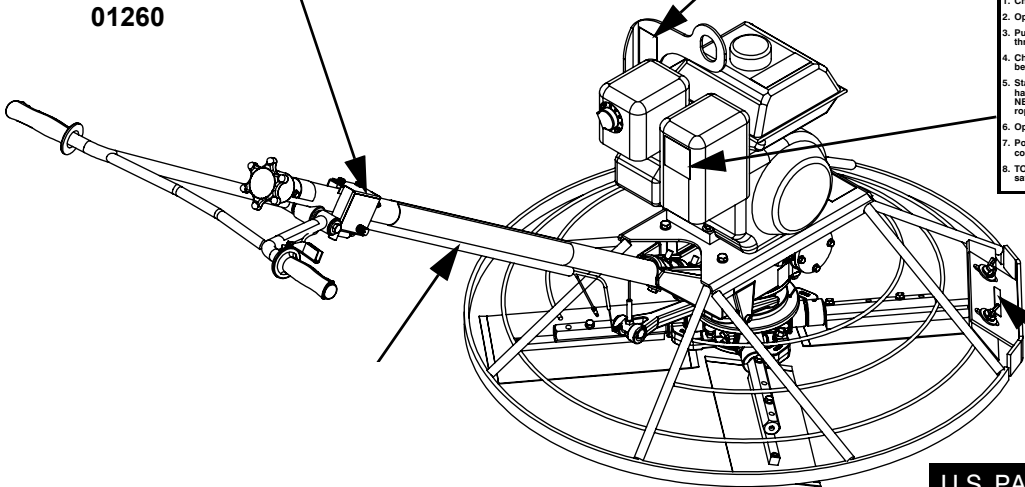

U.S. PATENT 4,027,991

05950

Safety Decals (Decal Kit #19975)

⚠ WARNING Spring under tension!
Consult manual before attempting service. 16167

16167
Not included
with decal kit

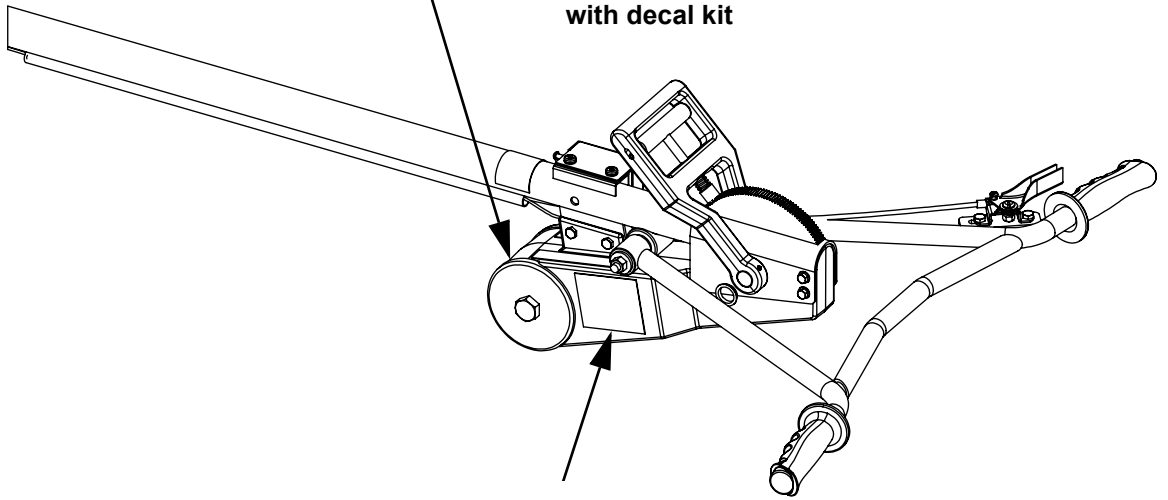

16168
Not included
with decal kit

⚠ WARNING
OPERATION OF THIS EQUIPMENT MAY
CREATE SPARKS THAT CAN START FIRES
AROUND DRY VEGETATION. A SPARK
ARRESTER MAY BE REQUIRED. THE
OPERATOR SHOULD CONTACT LOCAL FIRE
AGENCIES FOR LAWS OR REGULATIONS
RELATING TO FIRE PREVENTION. 19791

19791
Not included
with decal kit

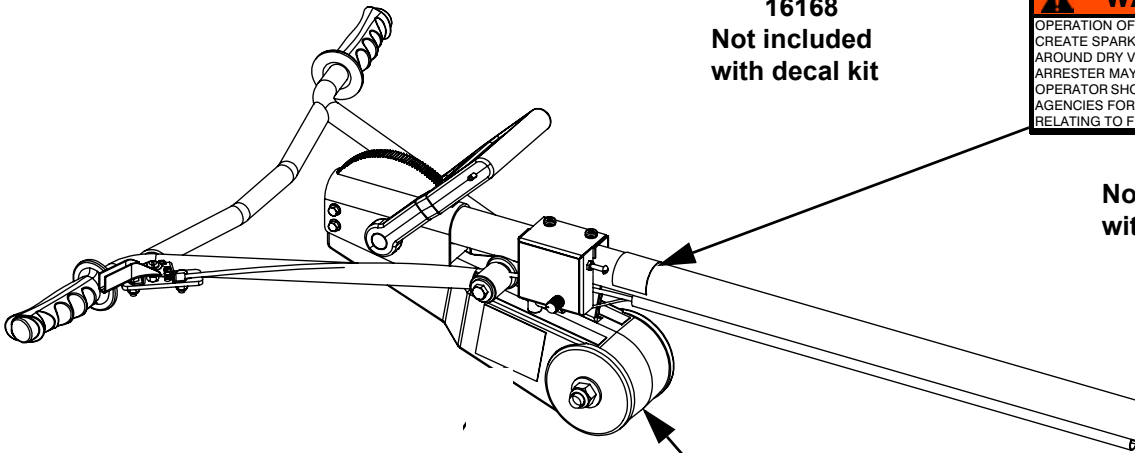

⚠ WARNING Spring under tension!
Consult manual before attempting service. 16167

16167
Not included
with decal kit

Safety Decals - Constant Force Pitch Handle

SPECIFICATIONS

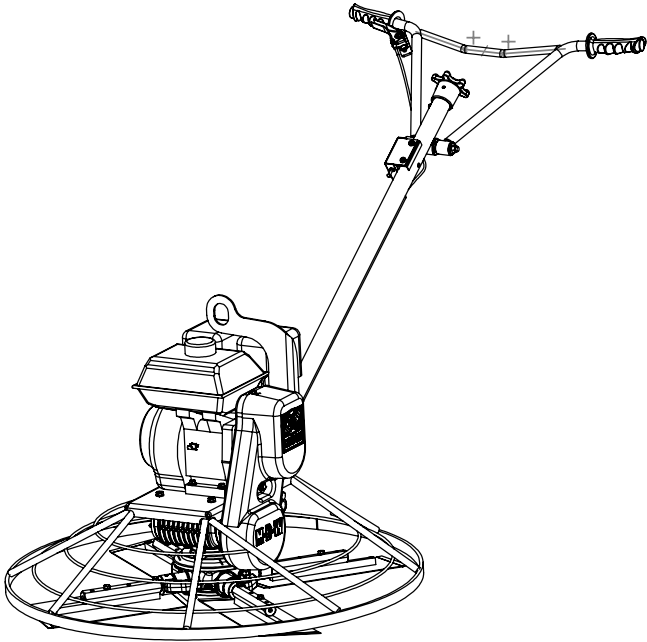

F36/4

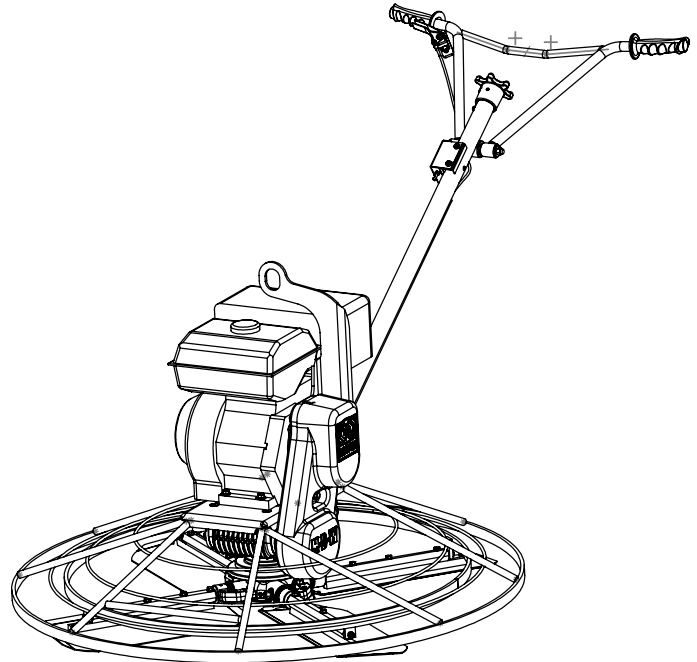

F46/4

	F36/4	F46/4	F46/4HD
Ring Operating Diameter (Outside Diameter)	37-1/2 in (95 cm)	46 in (117 cm)	46 in (117 cm)
Gas Engines	GX160 Honda (9.9 in ³ /163cc) GX270 Honda (16.5 in ³ /270cc) EX17 Robin(10.3 in ³ /169cc) EX21 Robin(12.9 in ³ /211cc)	GX270 Honda (16.5 in ³ /270cc) GX390 Honda (23.7 in ³ /389cc) EX21 Robin(12.9 in ³ /211cc) EX27 Robin(16.2 in ³ /265cc)	GX390 Honda (23.7 in ³ /389cc)
Engine Speed	3400 rpm	3400 rpm	3400 rpm
Trowel Speed	70 - 135 rpm	70 - 135 rpm	70 - 135 rpm
Weight	174 lbs (79 kg) [GX160] 200 lbs (91 kg) [GX270] 174 lbs (79 kg) [EX17] 176 lbs (80 kg) [7EX21]	243 lbs (110 kg) [GX270] 257 lbs (117 kg) [GX390] 224 lbs (102 kg) [EX21] 230 lbs (104 kg) [EX27]	293 lbs (129 kg)
Noise Level¹	85 - 105 dBA	85 - 105 dBA	85 - 105 dBA

Specifications subject to change without notice

1. Noise levels are based on operating conditions and will vary with background noise

OPERATION

Introduction

MBW equipment is intended for use in very severe applications. They are powered by four cycle engines and are available in different sizes and a selection of engines.

This parts manual contains only standard parts. Variations of these parts as well as other special parts are not included. Contact your local MBW distributor for assistance in identifying parts not included in this manual.

Before Starting & Operating

- **REMEMBER!** It is the owner's responsibility to communicate information on the safe use and proper operation of this unit to the operators.
- Review ALL of the Safety Precautions listed on page 1 of this manual.
- Familiarize yourself with the operation of the machine and confirm that all controls function properly.
- Know how to STOP the machine in case of an emergency.
- Make sure hands, feet, and clothing are at a safe distance from any moving parts.
- **NEW TROWELS** - After assembling the handle, inspect the throttle connections and confirm the remote throttle is actuating the engine throttle properly and all controls function properly.
- **FUEL SUPPLY** - The engines on MBW Power Trowels require a good grade of unleaded automotive gasoline. See the engine owner's manual for specific details. Engines are NOT approved to run E85 fuel.
- **ENGINE OIL** - Check the oil level in the engine. Refer to the Lubrication section of the engine owner's manual.
- **GEARBOX OIL** - Check the oil level in the trowel gearbox. Refer to the Maintenance section of this manual.
- **AIR CLEANER** - Check to make sure the element is in good condition and properly installed. Clean or replace filter element if clogged or damaged.

Starting Engine

1. Open fuel valve.
2. Turn engine switch to "ON".
3. Turn trowel safety switch to "ON".
4. Set throttle to idle.
5. Choke engine if necessary (you may not need to choke a warm engine).
6. Place one hand on the trowel handle and the other on the starter rope. Pull starter rope repeatedly until engine starts.



WARNING



NEVER place foot inside the guard ring when starting.

7. Move choke lever to open position and allow engine to warm up for one or two minutes.

Operating

1. Increase throttle to engage the clutch.
2. Set throttle to desired position to achieve the appropriate trowel blade speed.
3. To move forward, push down on the right handle grip and pull up on the left handle grip.
4. To move backward, pull up on the right handle grip and push down on the left handle grip.
5. To move left, pull up on both handle grips.
6. To move right, push down on both handle grips.

Blade Pitch Adjustment (Standard)

1. To increase the pitch, rotate the tilt knob clockwise.
2. To decrease the pitch, rotate the tilt knob counterclockwise.

Blade Pitch Adjustment (Constant Force)

1. To increase the pitch, squeeze the trigger and pull the lever towards you.
2. To decrease the pitch, squeeze the trigger and push the lever away from you.

Handle Bar Adjustment

1. Loosen bolt securing the handle bar to trowel handle.
2. Move handle bar to desired position.
3. Tighten bolt to lock handle.

Stopping Engine

1. Move throttle to idle position.
2. Turn trowel safety switch to "OFF".
3. Close the fuel valve.



WARNING



Always stop the engine before:

Adding fuel.

Leaving the equipment unattended for any amount of time.

Before making any repairs or adjustments to the machine.

MAINTENANCE



WARNING



Always exercise the stopping procedure before servicing or lubricating the unit.

After servicing the unit, replace and fasten all guards, shields, and covers to their original positions before resuming operation.



CAUTION



Always verify fluid levels and check for leaks after changing fluids.

Do not drain oil onto ground, into open streams, or down sewage drains.

Maintenance Schedule

MAINTENANCE	10 HOURS OR DAILY	50 HOURS OR WEEKLY	100 HOURS OR MONTHLY	500 HOURS OR YEARLY
Grease yoke plate	X			
Grease spider	X			
Change gearbox oil				X
Check gearbox oil	X			
Inspect drive belt		X		
Check and tighten all hardware ¹			X	

1. Check all hardware after the first 5 hours of use, then follow the maintenance schedule.

Fluid Levels

SYSTEM	FLUID VOLUME	RECOMMENDED OIL
Gearbox Oil	21 oz. (620 ml)	#680 140wt Sulfur Free (MBW #05700)
Engine	Refer to engine operator/owner manual	

Engine Maintenance

Refer to the engine owner's manual for maintenance intervals and procedures.

Engine Oil

Refer to the engine owner's manual for recommended oil change intervals.



WARNING



Never change the oil when engine is hot. Allow engine to cool before maintaining.

To drain the oil, lift and tip the trowel forward onto the guard ring using the trowel handle. Place a drain pan underneath the engine and remove the drain plug. After the oil has finished draining, reinstall the plug and clean any spilled oil from the trowel.

Engine Speed

The engine speed is factory preset according to the Specifications section. Do not tamper with the governor settings. The governor establishes safe operating limits. These limits must not be exceeded.

Cleaning

Always clean the trowel thoroughly after each day's operation. Dried concrete buildup can hinder performance and shorten the life of the trowel.

Lubrication

- Grease the yoke plate and spider (see Spider Assembly, page 16) every 10 hours or daily with a lithium base, low temperature, general purpose lube.
- Change the gearbox oil once every season or 500 hours, whichever comes first. The drain/fill plug is located on the right-hand side of the gearbox. Fill it with 21 oz. (620 ml) of MBW Worm Gear Oil (MBW

#05700). The oil should be to the bottom of the fill hole when sitting level.

Lifting

The trowel should be lifted by the lifting bracket attached to the engine. As an alternative, it may be lifted by two people on opposite sides of the guard ring.

Storage

The trowel should be stored with blocks supporting the outer guard ring. Refer to the engine owner's manual for information regarding storage of the engine.

Changing Trowel Blades



WARNING



Trowel blade edges may be sharp when they are worn. Wear protective gloves when handling the blades.

1. Set the trowel on a level surface.
2. Remove the bolts securing the blade to the tilt arm.
3. Lift up on the ring guard and slide the blade out from under the tilt arm.
4. Slide the new blade under the tilt arm.
5. Reinstall the bolts and tighten.
6. Check that the carriage bolts are set properly. If they require adjustment refer to the "Setting Tilt Arm Carriage Bolt Height" section.

Setting Tilt Arm Carriage Bolt Height

1. Remove **ALL** the tilt arms from the spider.
2. Remove the blades from all the arms. Wear protective gloves when removing the blades, the edges may be sharp
3. Inspect the bottom side of the arms (blade mounting surface). Remove any nicks, cement, etc... **THIS SURFACE MUST BE FLAT**
4. Loosen the jam nut and run the carriage bolt in as far as possible.
5. Mount the arm to gage #07277 as shown in figure 4.

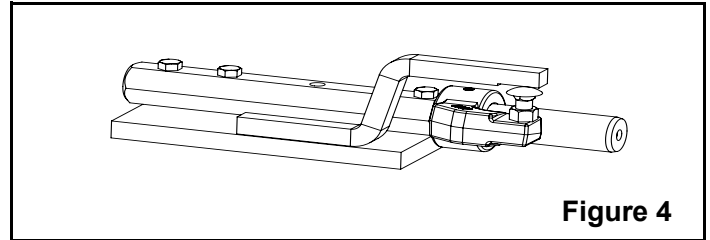

Figure 4

6. Place a .030 feeler gage between the carriage bolt and the underside of the gage arm, and run the carriage bolt up to just contacting the feeler gage. There should be a slight drag felt when the feeler gage is moved between the two surfaces.
7. Place a 3/8" open end wrench on the square shoulder of the carriage bolt and tighten the jam nut. **DO NOT** allow the carriage bolt to turn.
8. Recheck clearance with feeler gage and readjust if necessary.
9. Repeat items 5 through 8 for **ALL** remaining tilt arms.
10. Lubricate the tilt arm prior to fitting it in spider.

SERVICE

Assembly and disassembly should be performed by a service technician who has been factory trained on MBW equipment. The unit should be clean and free of debris. Pressure washing before disassembly is recommended.

- Prior to assembly, wash all parts in a suitable cleaner or solvent.
- Check moving parts for wear and failure. Refer to the Replacement section in this manual for tolerance and replacement cycles.
- All shafts and housings should be oiled prior to pressing bearings. Also, ensure that the bearings are pressed square and are seated properly.
- All bearings, seals, o-rings and gaskets should be replaced when rebuilding gearbox.

Torque Chart

SIZE	GRADE 2	GRADE 5	GRADE 8
1/4-20	49 in·lbs	76 in·lbs	9 ft·lbs
1/4-28	56 in·lbs	87 in·lbs	10 ft·lbs
5/16-18	8 ft·lbs	13 ft·lbs	18 ft·lbs
5/16-24	9 ft·lbs	14 ft·lbs	20 ft·lbs
3/8-16	15 ft·lbs	23 ft·lbs	33 ft·lbs
3/8-24	17 ft·lbs	26 ft·lbs	37 ft·lbs
7/16-14	24 ft·lbs	37 ft·lbs	52 ft·lbs
7/16-20	27 ft·lbs	41 ft·lbs	58 ft·lbs
1/2-13	37 ft·lbs	57 ft·lbs	80 ft·lbs
1/2-20	41 ft·lbs	64 ft·lbs	90 ft·lbs
9/16-12	53 ft·lbs	82 ft·lbs	115 ft·lbs
5/8-11	73 ft·lbs	112 ft·lbs	159 ft·lbs
5/8-18	83 ft·lbs	112 ft·lbs	180 ft·lbs
3/4-16	144 ft·lbs	200 ft·lbs	315 ft·lbs
1-8	188 ft·lbs	483 ft·lbs	682 ft·lbs
1-14	210 ft·lbs	541 ft·lbs	764 ft·lbs
1-1/2-6	652 ft·lbs	1462 ft·lbs	2371 ft·lbs
M 6	3 ft·lbs	4 ft·lbs	7 ft·lbs
M 8	6 ft·lbs	10 ft·lbs	18 ft·lbs
M 10	10 ft·lbs	20 ft·lbs	30 ft·lbs
CONVERSIONS			
in·lbs x 0.083 = ft·lbs			
ft·lbs x 12 = in·lbs			
ft·lbs x 0.1383 = kg·m			
ft·lbs x 1.3558 = N·m			

Service Tools

Part No.	Description
07276	Adjustment Tool, Tilt Arm Parallelism
07277	Adjustment Tool, Tilt Arm Height Gage
07279	Installation Tool, Spider Bushing (#06459)
16421	Bearing Spool Tool (Constant Force)

Gearbox Disassembly

Refer to Gearbox Assembly, page 14.

1. Remove the handle, belt guard & drive assembly (page 18), engine & guard ring (page 20).
2. Loosen the square head set screw (page 16, #20) until the gearbox housing can be lifted off the spider assembly.
3. Flip the gearbox housing (#7) over and set it on the four guard ring pads.
4. Remove the yoke arm (#9) by removing one of the retaining rings (#6), holding the pivot rod (#12) and sliding the rod out of the holes.
5. Remove the two flange bolts (#24) and the two flat head screws (#25) that hold the cover (#8) to the gearbox housing (#7).
6. Remove the cover and discard the shims (#11) and the o-ring (#5).
7. Pull out the shaft (#14) with the bearings (#3) and the worm gear (#13) and drain oil out of gearbox.
8. Press bearing (#3) and worm gear (#13) off long side of shaft (#14).
9. Remove key (#15) and retaining ring (#2) from shaft.
10. Press remaining bearing (#3) off of shaft.
11. Remove the four flange bolts (#23) and the bearing cap (#20). Discard the shim gasket (#10) and the o-ring (#17).
12. Remove the worm shaft (#19) and the bearings (#22).
13. Remove the retaining cap (#21) and discard the shim gasket (#10) and the o-ring (#17).

Gearbox Assembly

Refer to Gearbox Assembly, page 14.

1. Lightly oil the shaft (#14). Install the key (#15) and the retaining ring (#2) onto the shaft.
2. With the retaining ring end of the shaft down, press the worm gear (#13) onto the shaft. Make sure the

longer hub of the worm gear is down. The worm gear should be pressed on the shaft until the recess in the worm gear hub is snug against the retaining ring.

3. Press one bearing (#3) on each end of the shaft. Make sure the bearings are butted against the worm gear shoulders.
4. If the bearing races are replaced make sure the new races are properly seated.
5. Set the worm gear and the shaft assembly into the gearbox housing and put cover (#8) and one .010" shim #05401 (#11) into place.
6. Apply down pressure to cover (#8) and check shaft (#14) for end play.
7. Remove the cover and install the proper shims (#11) for no end play.
8. Brush a light coat of oil on the o-ring groove and inside the lip of the cover. Roll the o-ring (#5) over the inside lip and into the groove in the cover. Install the seal (#1) into the cover from the outside and make sure it is installed square and flat.
9. Use a piece of thin plastic over the shaft to protect the seal and install the cover into the gearbox housing and secure it with two flange bolts (#24) and two flat head screws (#25).
10. Rotate the shaft, there should be a little drag. If there is too much drag another shim should be added until a slight seal drag is felt. If there is side play in the shaft a shim must be removed.
11. Measure the main shaft run out. Maximum acceptable total indicator run out is .0035 inches.
12. Install the drain plug (#26) and relief valve (#16) if removed. Use pipe sealant on the threads before installation.
13. Brush a light coat of oil on the o-ring (#17). Roll it over the inside lip and into the groove of the retaining cap (#21).
14. Install two .010" shims #05360 (#10) with the retaining cap on the drain plug side of the gearbox housing with four flange bolts (#23). Torque the bolts to 90 in/lbs in an "X" pattern.
15. Press one bearing (#22) on each end of the worm shaft (#19). Make sure the bearings are butted against the worm shaft steps.
16. Install the worm shaft (#19) with the bearings (#22) into the gearbox housing. The gears must be meshed properly.
17. Install the bearing cap (#20) and apply pressure towards gearbox (#7). Rotate the worm shaft and check for end play and gear backlash.
18. Remove the bearing cap and install the proper shims (#10) for no back lash & no end play.

19. Install a new seal (#18) into the bearing cap (#20) from the outside. Make sure the seal is installed square and flat.
20. Brush a light coat of oil on the o-ring groove. Roll the o-ring (#17) over the inside lip and into the groove of the bearing cap.
21. Pour one can (21 oz.) of #05700 oil into the worm shaft bearing cap opening. Install the cap and secure it with four flange bolts (#23). Torque the bolts to 90 in/lbs in an "X" pattern.

CFP Handle Cable/Spring Replacement

Refer to Constant Force Handle Assembly, page 24.

1. Remove handle assembly from machine.
2. Support handle assembly in a vise to secure for disassembly.
3. Loosen handle pivot bolt (#41) and fold handle forward.
4. Remove the four bolts (#32) on the back of the springbox.
5. Carefully rotate lever (#19) arm backwards until you feel the cable tension release. When it releases there will be no spring tension on the lever (#19) in either direction.
6. Remove spring retainer bolt (#45) and end covers (#26).
7. Remove remaining two bolts (#33) to separate spring box (#25) from handle.
8. With a long needle nose pliers, disconnect the cable from the spring.
9. If you are only replacing spring (#28) proceed with step 10. If you are replacing cable and/or clevis refer to step 13.
10. Note orientation of spring assembly. Remove bearing spool (# 29) by pushing it out either side.
11. Remove spring assembly by forcing it out either side.
12. Refer to step 18 for assembly.
13. Push threaded portion of cable into tube.
14. Slide clevis assembly out of tube toward the bottom.
15. Remove cable from tube.
16. Route barrel end of new cable into tube.
17. Route threaded portion of the cable over the pulley on clevis and back into the tube. Guide the threaded end through the slot in the handle as you insert clevis into the handle tube. Insert one of the handle bolts through the clevis mounting holes to hold it in place. See figure 7.
18. Install spring (#28) into spring box (#25). Note bearing spool must be removed to get spring into housing.

19. Install bearing spool into spring with #16421 tool. Tighten a nut on the threaded rod of the tool against the cover of the spring box to pull the tapered pin into the spring. Once the spring is spread, the spool can be inserted behind the tapered pin and the tool can be removed.

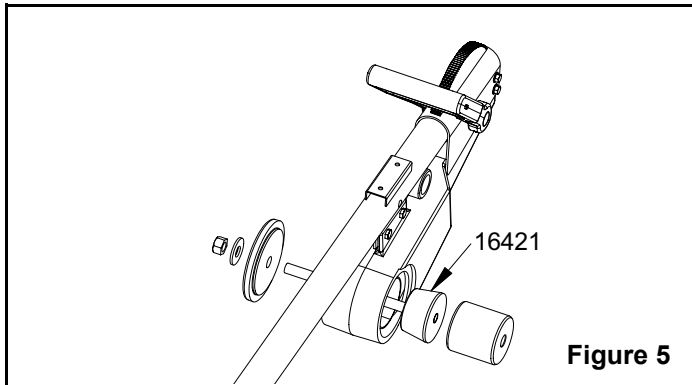

Figure 5

20. Hook cable end to spring (#28) and route cable around activating cam (#18).
21. Install spring box side covers (#26) and secure in place with hardware.
22. Mount spring box onto handle using center mount point only. Align rear mounting holes but do not install bolts. Tighten center mount bolts.
23. To engage cable pin in activating cam slot it will be necessary to apply tension to the threaded portion of the cable. This can be done by tightening a nut against a spacer, such as a deepwell socket, on the threaded end. While applying tension, rotate the lever arm backwards until you feel the cable pin snap into its slot. Once in place you will have constant tension on the lever arm. Rotate the lever arm forward and release the trigger to lock the lever.

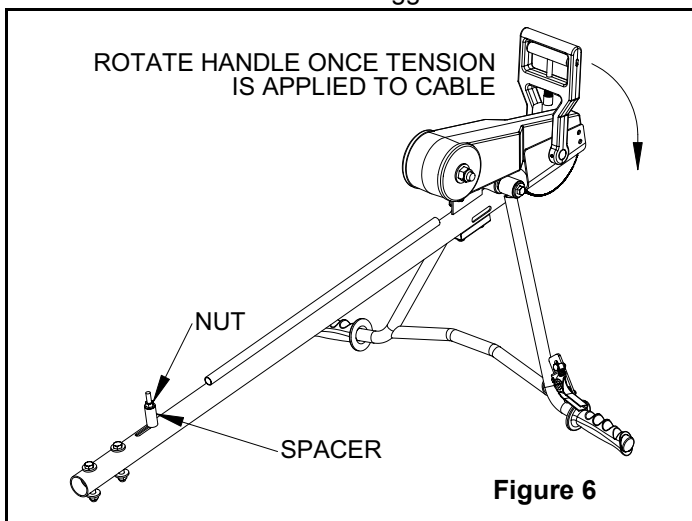

Figure 6

24. Install the remaining 4 bolts (#32).
25. Tighten the handle pivot bolt (#41).
26. Install handle on trowel.

Standard Handle Pitch Cable Replacement

Refer to Handle Assembly, page 22.

1. Remove handle assembly from trowel.
2. Remove switch assembly (#11). It is not necessary to disconnect the wire.
3. Turn pitch control knob all the way counterclockwise.
4. Spiral pin (#27) should be aligned with hole on left and slot on right.
5. Drive pin out toward the slot just far enough to unhook cable.
6. Slide clevis (#5) out of the tube and remove cable.
7. Since it is not possible to thread the cable while the clevis is in the tube, it must be put through the pulley with the clevis removed.
8. Route both ends of the cable into the bottom of the tube. The threaded end must come out of the slot.

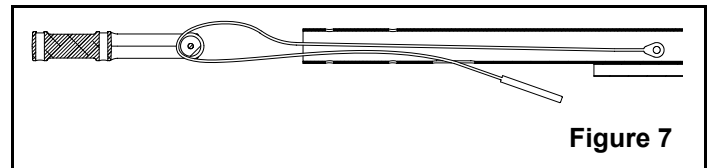

Figure 7

9. Insert clevis with cable into tube. Use a handle bolt to hold clevis in place.
10. Push cable up align eyelet with spiral pin hole.
11. Press spiral pin in flush with outside of slot on handle.
12. Install switch on handle.
13. Install handle on trowel.

Spider Bushing Removal

Refer to Figure #8

1. Screw a 3/4-14 pipe tap about half way into the worn outer bushing.
2. Insert a 3/4" x 8 1/2" push rod into the opposite side of the spider.
3. Use a 1 1/4" x 4" tube on upper end to press old bushings out.
4. Repeat with inner bushings.

Spider Bushing Replacement

Refer to Figure #9 for bushing installation:

1. Install (4) inner bushings into spider, using long side of installation tool #60703 to ensure proper bushing depth.

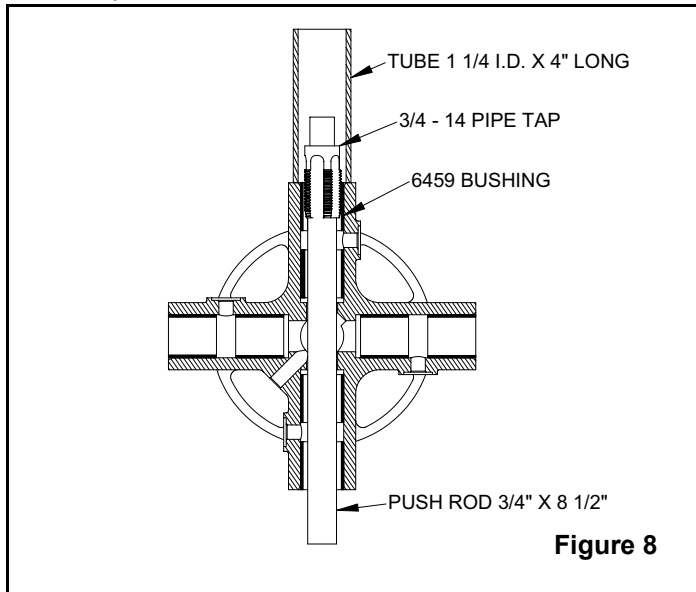

2. Using the opposite end or short end of installation tool #60703, install (4) outer bushings into spider.

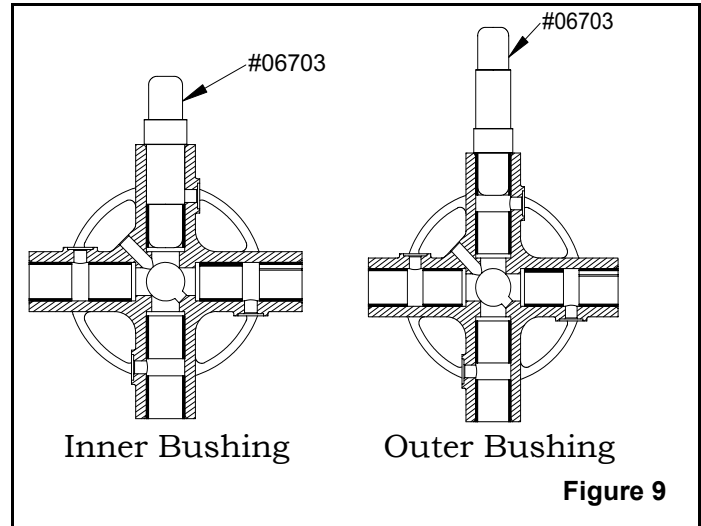

Parts Replacement Cycles and Tolerances

Air Cleaner Element	Replace after 100 hours if the engine is operating under good clean air conditions. Service and replace more frequently if under more severe conditions.
Bearings	Replace anytime a bearing is rough, binding, discolored or removed from housing or shaft.
Blades	Replace when the edges become sharp or uneven. (Finish blades can be reversed)
Bushings, Trowel Arm	Replace if the trowel arm can be moved up and down more than 3/4 inch (19 mm) at the end of the arm.
Carriage Bolts	Reset the height after trowel arm teardown or if the trowel develops chatter or windmilling. Use height gage kit #07277 when setting.
Clutch	Replace clutch if it does not disengage below 2000 rpm.
Gaskets and Seals	Replace at every overhaul and teardown. Use MBW gasket and seal kit #05470.
Gearbox Oil	Replace after the first 50 hours of operation, then every 500 operating hours or yearly thereafter.
Spark Plug	Change after 75 hours of operation.
Torque Bolts	Re-torque all the bolts after the first eight hours of operation and check every 25 hours thereafter.
Worm Gear	Replace if the teeth show wear marks or become sharp.
Worm Shaft	Replace if the teeth show wear marks or become sharp.

REPLACEMENT PARTS

The warranty is stated in this book on page 26. Failure to return the Warranty Registration Card renders the warranty null and void.

MBW, Inc. has established a network of reputable distributors with trained mechanics and full facilities for maintenance and rebuilding, and to carry an adequate parts stock in all areas of the country. Their sales engineers are available for professional consultation. If you cannot locate an M-B-W distributor in your area, contact MBW, Inc. or one of our Sales Branches listed below.

When ordering replacement parts, be sure to have the following information available:

- Model and Serial Number of machine when ordering M-B-W parts
- Model and Serial Number of engine when ordering engine parts
- Part Number, Description, and Quantity
- Company Name, Address, Zip Code, and Purchase Order Number
- Preferred method of shipping

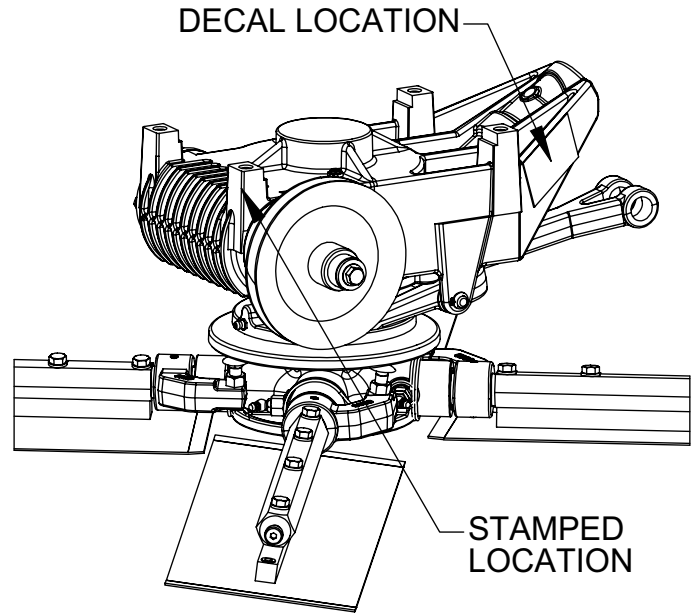

The unit's serial number can be found in the following locations:

- The model/serial number decal is located on the rear side of the gearbox, next to the engine and beltguard.
- The serial number is stamped on the front of the gearbox.

Write Model Number here

Write Serial Number here

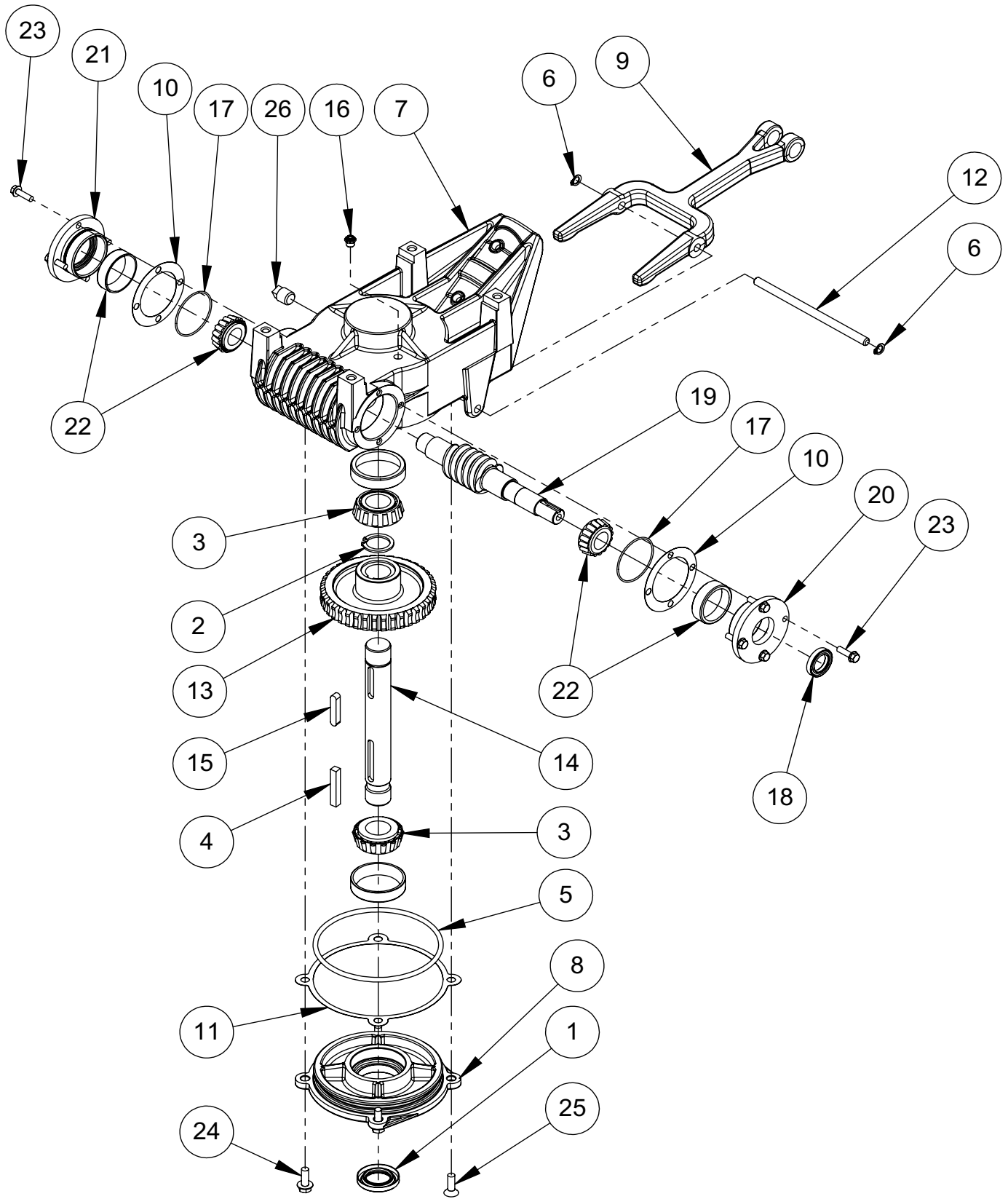

Gearbox Assembly

ITEM	PART NO.	DESCRIPTION	QTY
1.	01243	SEAL, GEAR SHAFT	1
2.	01244	RETAINING RING, EXTERNAL	1
3.	01251	BEARING TAPER ROLLER (Includes Bearing & Cup)	2
4.	01254	KEY, 5/16 SQUARE x 2 lg.	1
5.	01256	O-RING	1
6.	01279	RETAINING RING, EXTERNAL	2
7.	05323	HOUSING, GEARBOX	1
8.	05326	COVER, GEARBOX	1
9.	05329	ARM, YOKE	1
10.	05359	SHIM GASKET, 0.004"	
	05360	SHIM GASKET, 0.010"	
11.	05361	SHIM GASKET, 0.004"	
	05401	SHIM GASKET, 0.010"	
12.	05396	ROD, PIVOT	1
13.	05521	GEAR, WORM	1
14.	05523	SHAFT, OUTPUT	1
15.	05524	KEY, 5/16" SQUARE x 1-11/16" LONG	1
16.	06037	VALVE, RELIEF	1
17.	06392	O-RING	2
18.	11075	SEAL, INPUT SHAFT	1
19.	19637	WORM SHAFT	1
20.	19638	BEARING CAP	1
21.	19639	CAP, RETAINING	1
22.	19687	BEARING TAPER ROLLER (Includes Bearing & Cup)	2
23.	F042007FWS	FLANGE BOLT, 1/4-20 x 7/8"	8
24.	F051807FWS	FLANGE BOLT, 5/16-18 x 7/8"	2
25.	F051808FSS	FLAT HEAD SCREW, 5/16-18 x 1"	2
26.	F0618SHPP	PIPE PLUG, 3/8"	1
		REPLACEMENT KITS	
	19940	KIT, GASKET & SEAL (includes 1, 11, 12, 18 & 19)	
	19636	GEARBOX ASSEMBLY (includes all above items)	
	05700	GEAR OIL, CHEVRON #680	

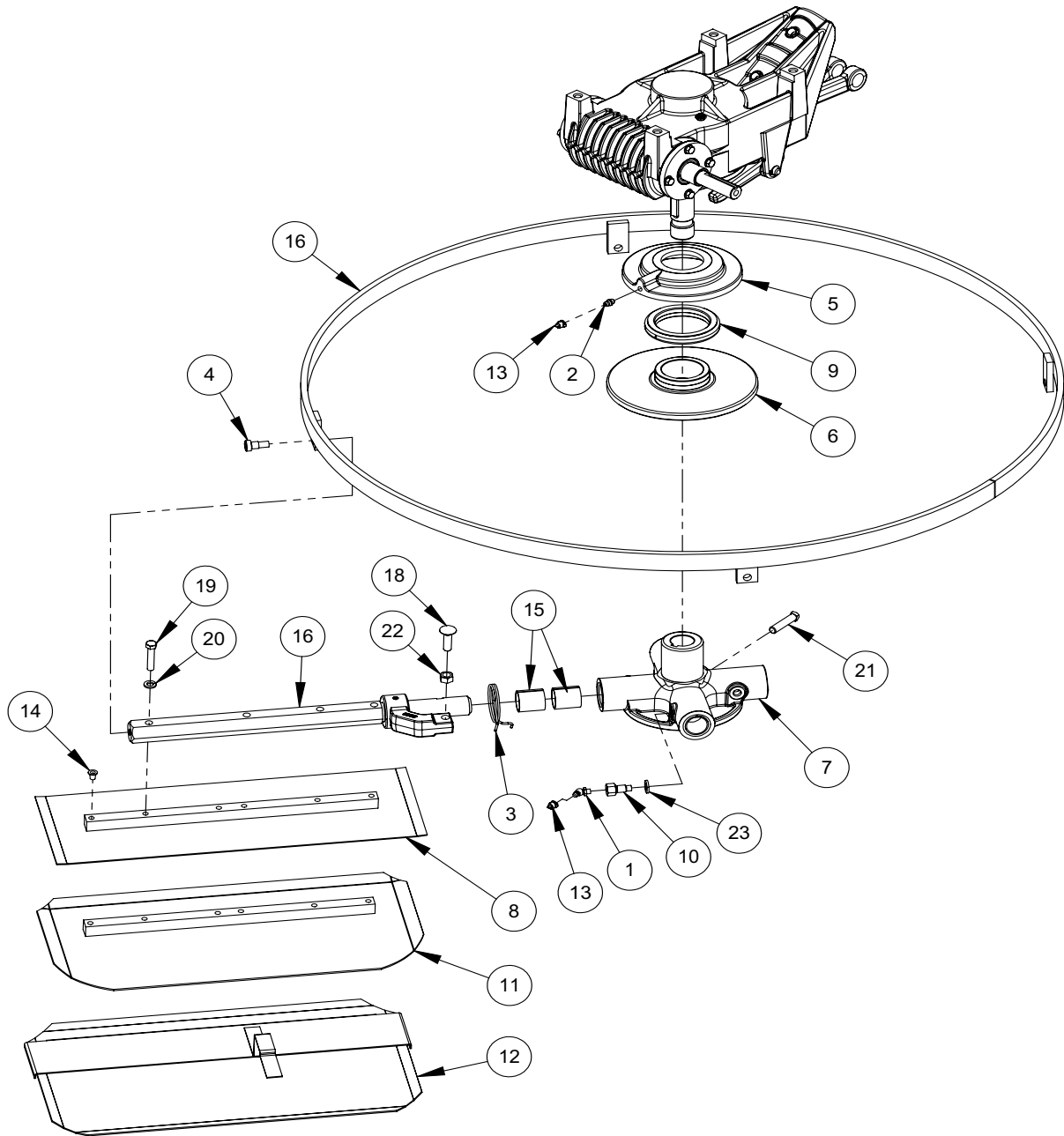

Spider Assembly

ITEM	PART NO.	DESCRIPTION	F36/4	F46/4
1.	01169	GREASE FITTING, 45	4	4
2.	01177	GREASE FITTING, STRAIGHT	1	1
3.	01258	SPRING	4	4
4.	01280	SOCKET HEAD SHOULDER SCREW, 3/8" x 3/8"		4
5.	05324	YOKE PLATE	1	1
6.	05330	PRESSURE PLATE, 4-ARM*	1	1
7.	05331	SPIDER, 4-ARM (includes 14)*	1	1
8.	05347	FINISH BLADE, 6" x 14"	4	
	05383	FINISH BLADE, 6" x 18"		4
9.	05356	BEARING	1	1
10.	05397	BOLT, HOLLOW	4	4
11.	05402	COMBINATION BLADE, 8" x 14"	4	
	05412	COMBINATION BLADE, 8" x 18"		4
12.	05403	FLOAT BLADE, 10" x 14"	4	
	07935	FLOAT BLADE, 10" x 18"		4
13.	05492	CAP, GREASE	5	5
14.	05968	CAPLUG (set of 12)	4	4
15.	06459	BUSHING, SPLIT	8	8
16.	06755	TILT ARM, 36" (includes 17 & 21)	4	
	07850	TILT ARM, 46" (includes 17 & 21)		4
17.	07870	STABILIZER, 4-ARM*		1
18.	17190	CARRIAGE BOLT (SPECIAL), 3/8-16 x 1-1/4"	4	4
19.	F051812HCS	HEX HEAD CAP SCREW, 5/16-18 x 1-1/2"	8	16
20.	F05LW	LOCKWASHER, 5/16"	8	16
21.	F061614SHS	SQUARE HEAD SET SCREW, 3/8-16 x 1-3/4"	1	1
22.	F0616HN	HEX NUT, 3/8-16	4	4
23.	F06LW	LOCKWASHER, 3/8"	4	4
		REPLACEMENT KITS		
	01427	GREASE FITTING CAPS (sold in sets of 12)	5	5
	06199	SPIDER & ARM ASSEMBLY, 4-ARM (includes 1, 3, 7, 10, 15, 20 & 22)	1	
	07898	SPIDER & ARM ASSEMBLY, 4-ARM (includes 1, 3, 7, 10, 15, 20 & 22)		1
	07524	PRESSURE PLATE ASSEMBLY, 4-ARM (includes 5, 6 & 9)	1	1
		*3-arm parts are no longer available, order 4-arm parts		

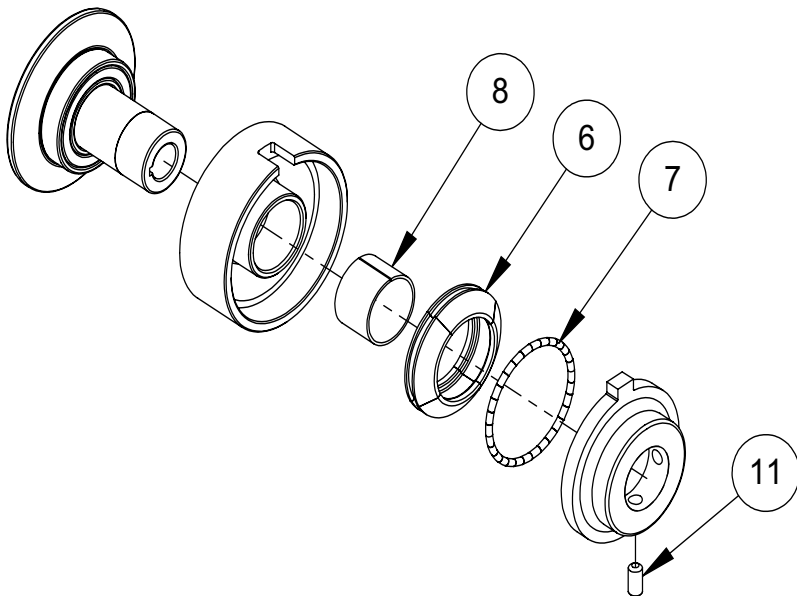
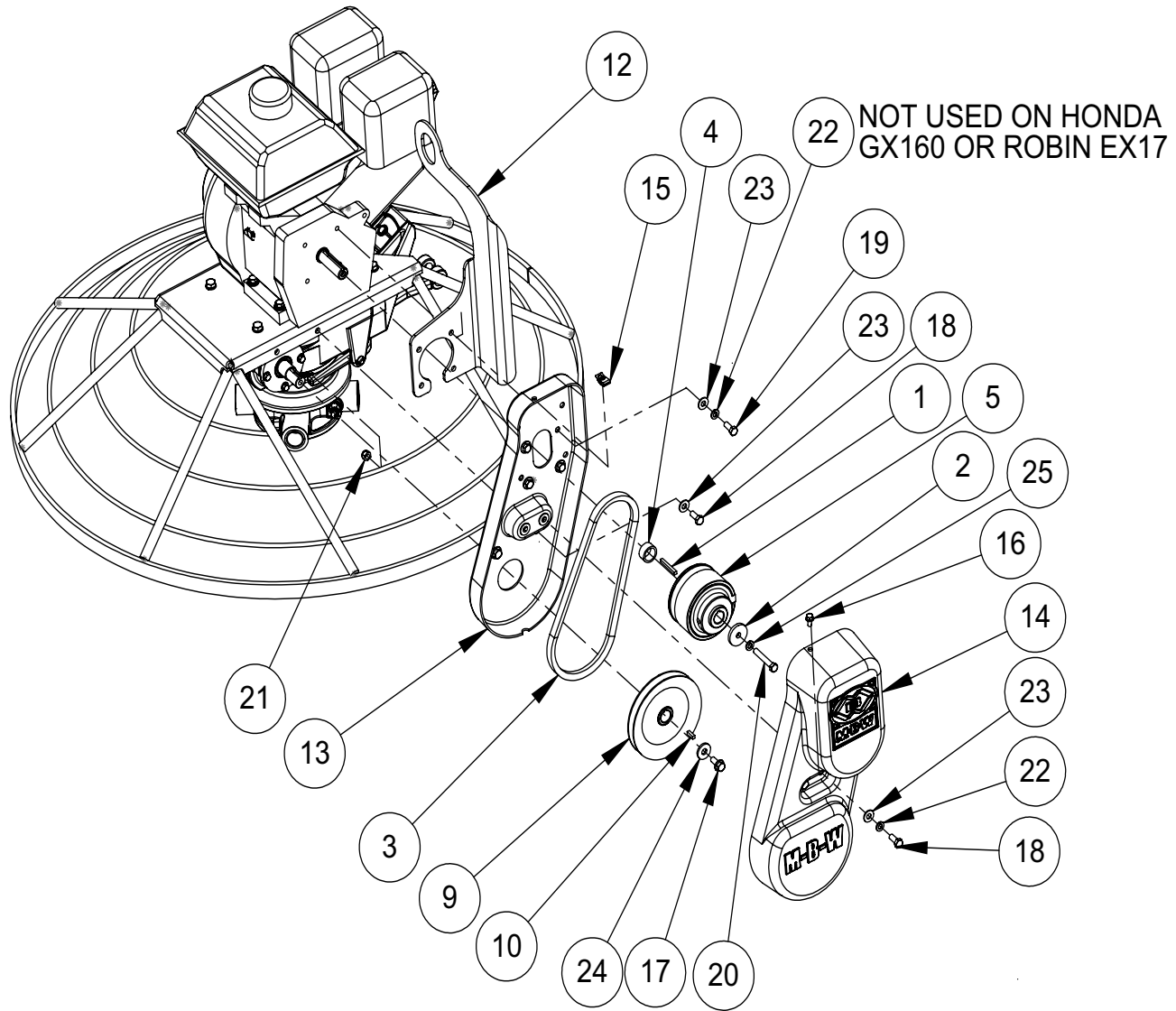

Drive Assembly

ITEM	PART NO.	DESCRIPTION	HONDA GX160	ROBIN EX17	ROBIN EX21	HONDA GX270	HONDA GX390
1.	00032 01161	KEY, 3/16" SQUARE x 1-5/8" LONG KEY, 1/4" SQUARE x 1-1/2" LONG	1	1	1	1	1
2.	01099 06638	WASHER, 5/16" SPECIAL WASHER, 3/8" SPECIAL	1	1	1	1	1
3.	01289 01078	V-BELT, A-27 V-BELT, A-29	1	1	1	1	1
4.	07288 06378	V-BELT, A-32 (F46/4HD only) SPACER	1	1	1	1	1
5.	06473 06606	CLUTCH 3/4" BORE (includes 6,7,8 & 11) CLUTCH 1" BORE (includes 6, 7, 8 & 11)	1	1	1	1	1
6.	06618	WEIGHT (set of 4)	1	1	1	1	1
7.	06619	SPRING	1	1	1	1	1
8.	06620	BEARING	1	1	1	1	1
9.	06746	SHEAVE	1	1	1	1	1
10.	06858	KEY, 3/16" SQUARE x 5/8" LONG	1	1	1	1	1
11.	19401	SCOCKET HEAD CUP POINT SET SCREW, 5/16-18x5/8	1	1	1	1	1
12.	19370 19372	LIFTHOOK, TROWEL (Foe engines 5-7 hp) LIFTHOOK, TROWEL (Foe engines 9-13 hp)	1	1	1	1	1
13.	19666	BELT GUARD, BACK PLATE ASSEMBLY (Inclues item #15)	1	1	1	1	1
14.	19668	BELT GUARD, FRONT COVER	1	1	1	1	1
15.	19804	CLIP NUT, 1/4-20	1	1	1	1	1
16.	F042004FWS	FLANGE SCREW, 1/4-20 x 1/2"	1	1	1	1	1
17.	F051806FWS	FLANGE SCREW, 5/16-18 x 3/4"	1	1	1	1	1
18.	F051808HCS	HEX HEAD CAP SCREW, 5/16-18 x 1"	4	4	4	4	4
19.	F052406HCS F052408HCS	HEX HEAD CAP SCREW, 5/16-24 x 3/4" HEX HEAD CAP SCREW, 5/16-24 x 1"	4	4	4	4	4
20.	F052416HCS F072012HCS	HEX HEAD CAP SCREW, 5/16-24 x 2" HEX HEAD CAP SCREW, 7/16-20 x1-1/2"	1	1	1	1	
21.	F062410SCS F0518ELN	SCOCKET HEAD CAP SCREW, 3/8-24 x 1-1/4 NYLON LOCKNUT, 5/16-18	2	2	2	2	2
22.	F05LW	LOCKWASHER, 5/16"	2	2	2	6	6
23.	F05SW	WASHER, 5/16	8	8	8	8	8
24.	F06SW	WASHER, 3/8"	1	1	1	1	1
25.	F05LW	LOCKWASHER, 5/16"	1	1	1		
	F07LW F06LW	LOCKWASHER, 7/16" LOCKWASHER, 3/8"				1	1
		<u>KITS:</u>					
	20250	HEAVY WEIGHT TROWEL					1

GX160 THRU EX21

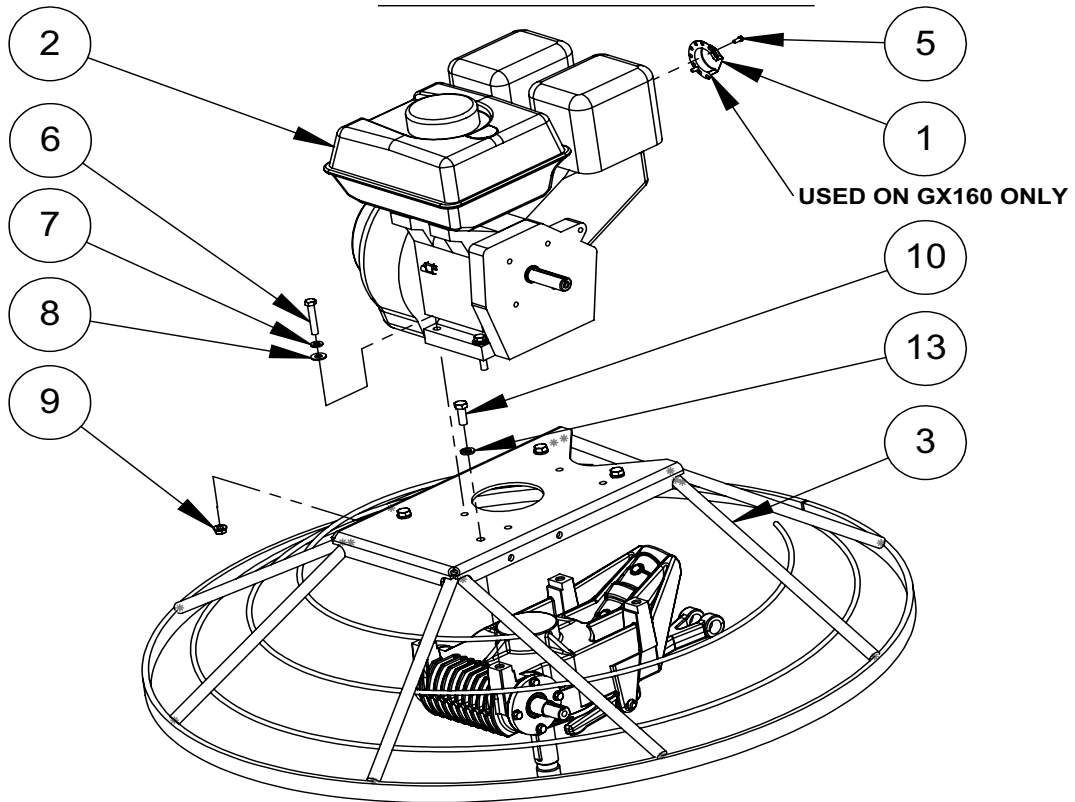

EX27 THRU GX390

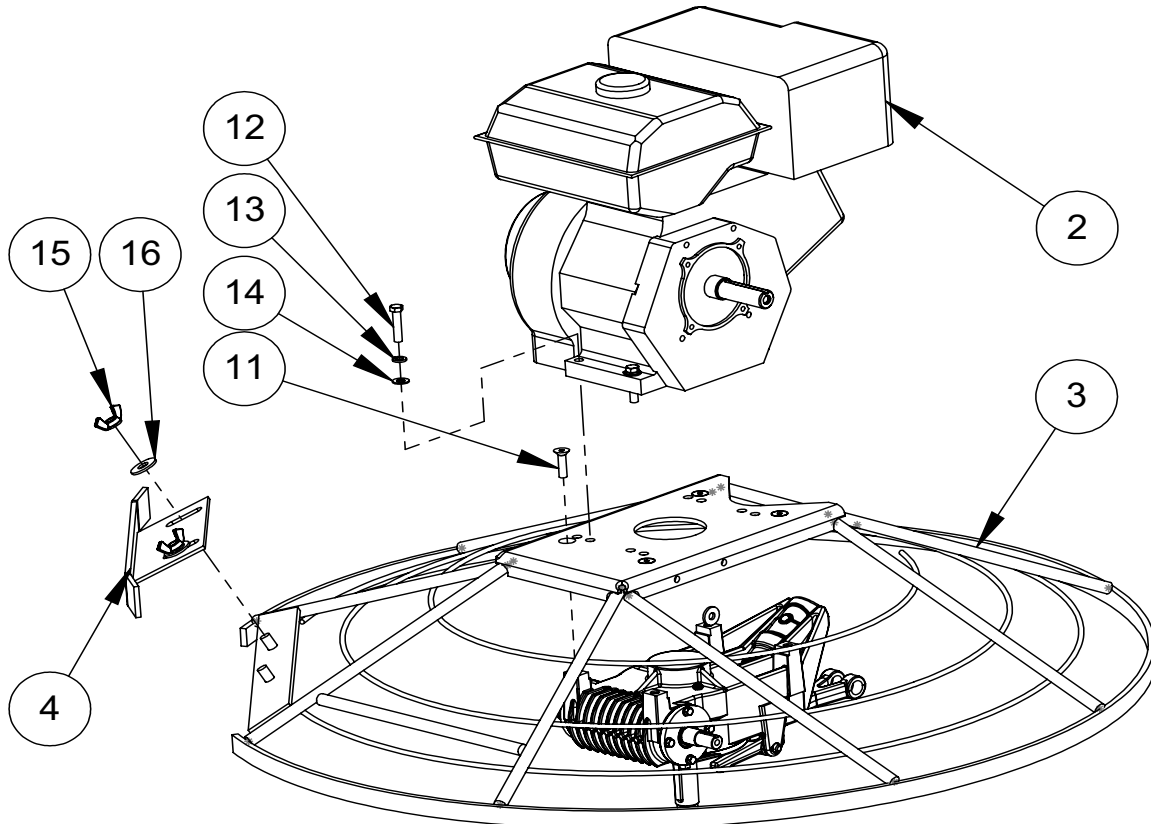

Guard Assembly

ITEM	PART NO.	DESCRIPTION	GX160 THRU EX21	EX27 THRU GX390	STD. RING	EDGER RING
1.	07636	EXHAUST DEFLECTOR (HONDA GX160 ONLY)	1			
2.	01444	HONDA ENGINE, GX160	1			
	17370	ROBIN ENGINE, EX17, 6 HP	1			
	17371	ROBIN ENGINE, EX21, 7 HP	1			
	17440	ROBIN ENGINE, EX27, 9 HP		1		
	15674	HONDA ENGINE, GX270		1		
3.	12887	HONDA ENGINE, GX390		1		
	19641	GUARD RING, 36" STANDARD			1	
	19643	GUARD RING, 36" EDGER				1
	19645	GUARD RING, 36" (9 HP) STANDARD			1	
	19647	GUARD RING, 36" (9 HP) EDGER				1
	19649	GUARD RING, 46" STANDARD			1	
4.	19651	GUARD RING, 46" EDGER				1
	19659	EDGER, 36"				1
	19938	EDGER, 46"				1
5.	F0203HTB	HEX TAP BOLT. #8 x 3/8" LG. (HONDA GX160 ONLY)	2			
6.	F051814HCS	HEX HEAD CAP SCREW, 5/16-18 x 1-3/4"	4			
7.	F05LW	LOCK WASHER, 5/16"	4			
8.	F05SW	FLAT WASHER, 5/16"	4			
9.	F0518FN	FLANGE NUT, 5/16-18	4			
10.	F061608HCS	HEX HEAD CAP SCREW, 3/8-16 x 1" (5-7 HP)	4	4		
	F051812HCS	HEX HEAD CAP SCREW, 5/16-18 x 1-1/2" (F46/4HD only)		4		
11.	F061612FSS	FLAT HEAD SCREW, 3/8-16 x 1-1/2" (9-13 HP)			4	4
12.	F061614HCS	HEX HEAD CAP SCREW, 3/8-16 x 1-3/4"		4		
13.	F06LW	LOCKWASHER, 3/8" (GUARD RING 5-7 HP ONLY)		4	4	4
14.	F06PW	PLAIN WASHER, 3/8"		4		
15.	F0813WN	WINGNUT, 1/2-13				2
16.	F08SW	WASHER, 1/2"				2
		REPLACEMENT KITS				
	Q2893881	AIR FILTER, GX100, HONDA ENGINE				
	Q5266721	AIR FILTER, GX270, HONDA ENGINE				
	Q2893907	AIR FILTER, GX3900, HONDA ENGINE				
		KIT, HEAVY WEIGHT TROWEL				

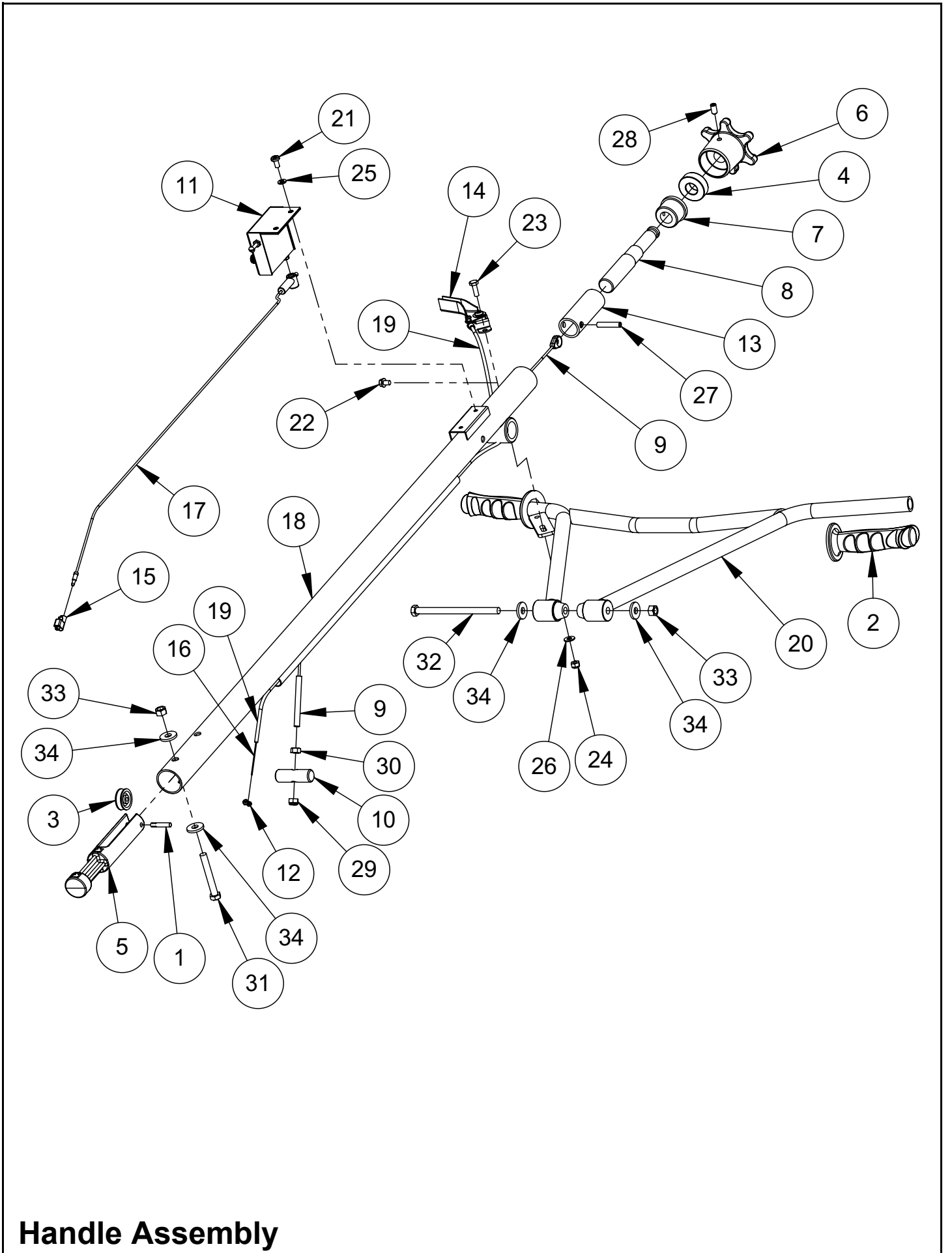

Handle Assembly

ITEM	PART NO.	DESCRIPTION	QTY
1.	01250	GROOVE PIN	1
2.	01253	GRIP	2
3.	01278	PULLEY	1
4.	01302	THRUST BEARING	1
5.	05357	CLEVIS	1
6.	05358	KNOB	1
7.	05363	BEARING	1
8.	05365	SHAFT	1
9.	05381	CABLE	1
10.	05395	PIVOT PIN	1
11.	05398	SAFETY SWITCH ASSEMBLY	1
12.	05477	SWIVEL	1
13.	05556	ADAPTER NUT	1
14.	06888	THROTTLE ASM (includes 23, 24 & 26)	1
15.	07592	SPLICE TERMINAL	1
16.	07662	WIRE	1
17.	07774	WIRE, SHORTING (63" long)	1
18.	07868	HANDLE	1
19.	07877	CASING	1
20.	11742	HANDLE BAR	1
21.	16047	SELF TAP SCREW, 1/4-20 x 1/2	2
22.	F042003FWS	FWLS, 1/4-20 x 3/8 ZP	1
23.	F042006HCS	HHCS, 1/4-20 x 3/4 ZP	2
24.	F0420ELN	ELASTIC LOCKNUT, 1/4-20	2
25.	F04LW	LOCKWASHER, 1/4	2
26.	F04PW	WASHER, 1/4	2
27.	F0512SP	SPIROL PIN, 5/16 x 1-1/2	1
28.	F051805SSS	SHSS, 5/16-18 x 5/8	1
29.	F0518ELN	ELASTIC LOCKNUT, 5/16-18	1
30.	F0518HN	HEX NUT, 5/16-18	1
31.	F061622HCS	HHCS, 3/8-16 x 2-3/4 ZP	2
32.	F061644HCS	HHCS, 3/8-16 x 5-1/2 ZP	1
33.	F0616DLN	DEFORMED LOCKNUT, 3/8	3
34.	F06SW	WASHER, 3/8	6
		REPLACEMENT PARTS	
	07876	HANDLE ASSEMBLY (includes all above items)	1
	19587	KIT, THROTTLE (includes items #12, #14, # 16 & #19)	

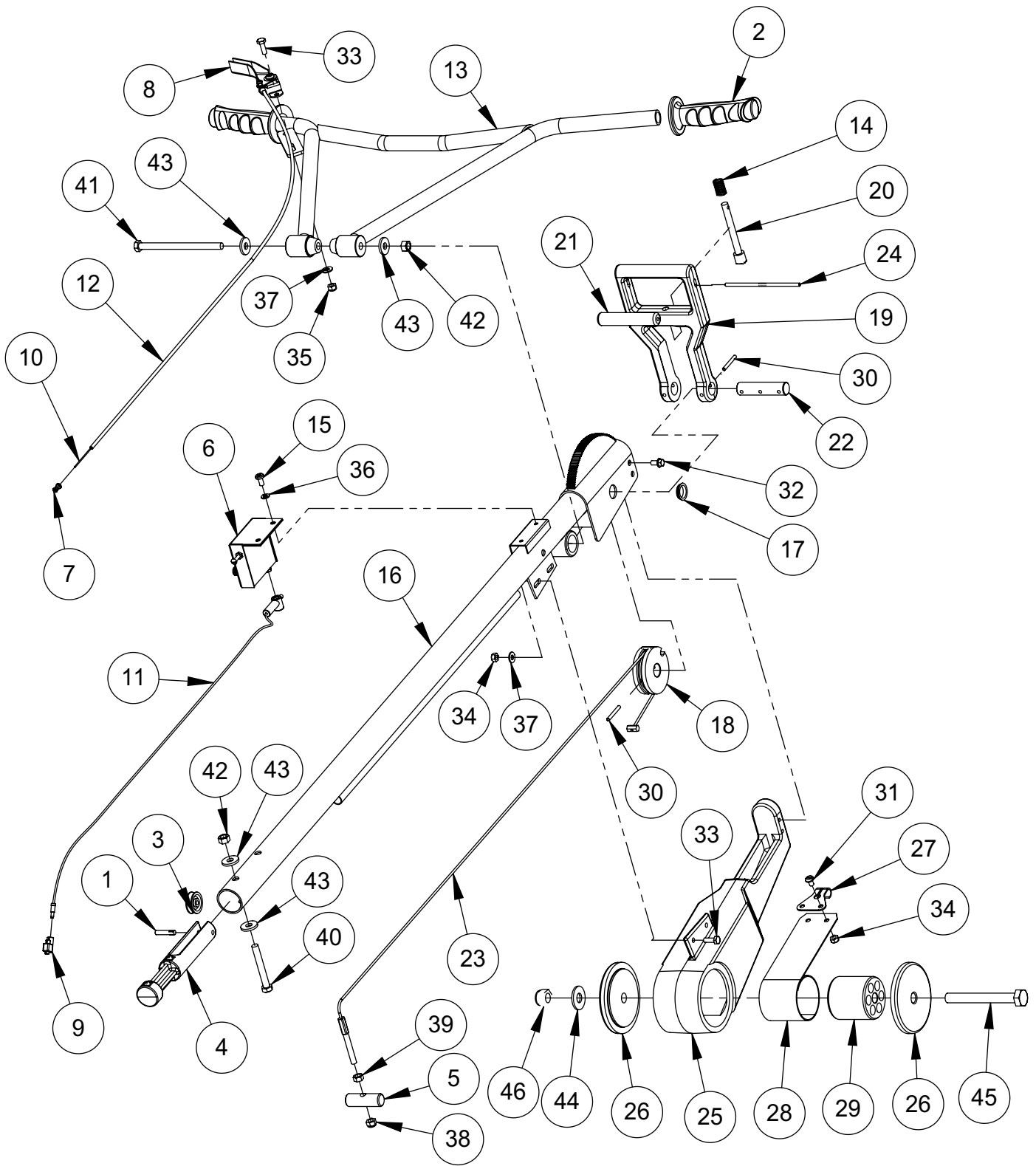

Constant Force Handle Assembly

ITEM	PART NO.	DESCRIPTION	QTY
1.	01250	GROOVE PIN	1
2.	01253	GRIP	2
3.	01278	PULLEY	1
4.	05357	CLEVIS	1
5.	05395	PIVOT PIN	1
6.	05398	SAFETY SWITCH ASSEMBLY	1
7.	05477	SWIVEL	1
8.	06888	THROTTLE ASM (includes 33, 35 & 37)	1
9.	07592	SPLICE TERMINAL	1
10.	07662	THROTTLE WIRE	1
11.	07774	SHORTING WIRE ASM	1
12.	07877	CASING	1
13.	11742	HANDLE BAR	1
14.	16040	COMPRESSING SPRING	1
15.	16047	SELF TAP SCREW, 1/4-20 x 1/2	2
16.	16075	HANDLE	1
17.	16078	CLIP BEARING	2
18.	16079	CAM, ACTIVATING	1
19.	16081	LEVER ARM	1
20.	16083	LOCK DOG	1
21.	16084	TRIGGER PULL	1
22.	16086	SHAFT, ACTIVATING	1
23.	16087	CABLE	1
24.	16099	DOWEL PIN, 3/16 x 5	1
25.	16370	SPRINGBOX	1
26.	16372	COVER	2
27.	16373	CABLE CLEVIS	1
28.	16374	CONSTANT FORCE SPRING	1
29.	16375	BEARING SPOOL	1
30.	F0312SP	SPIROL PIN, 3/6 x 1-1/2	3
31.	F042003PMS	PHMS, 1/4-20 x 3/8 ZP	2
32.	F042004FWS	FWLS, 1/4-20 x 1/2	4
33.	F042006HCS	HHCS, 1/4-20 x 3/4 GR5 ZP	4
34.	F0420DLN	DEFORMED LOCKNUT, 1/4-20	4
35.	F0420ELN	ELASTIC LOCKNUT, 1/4-20	2
36.	F04LW	LOCKWASHER, 1/4	2
37.	F04PW	WASHER, 1/4	4
38.	F0518ELN	ELASTIC LOCKNUT, 5/16-18	1
39.	F0518HN	HEX NUT, 5/16-18	1
40.	F061622HCS	HHCS, 3/8-16 x 2-3/4 GR5 ZP	2
41.	F061644HCS	HHCS, 3/8-16 x 5-1/2 GR5 ZP	1
42.	F0616DLN	DEFORMED LOCKNUT, 3/8	3
43.	F06SW	WASHER, 3/8	6
44.	F08SW	WASHER	2
45.	F091238HCS	HHCS, 9/16-12 x 4-3/4 GR5 ZP	1
46.	F0912ELN	ELASTIC LOCKNUT, 9/16-12	1
		REPLACEMENT PARTS	
	16080	LEVER ARM ASSEMBLY (includes 14, 19-21 & 24)	1
	16092	HANDLE ASSEMBLY (includes all above items)	1
	16367	SPRING SPOOL ASSEMBLY (includes 27-29, 31 & 34)	1

