



SLT5000 Handbook



DO NOT OPERATE THE GENERATOR BEFORE READING THIS MANUAL AND ENGINE MANUFACTURER'S OWNER'S MANUAL AND WARNINGS.

THIS STEPHILL GENERATOR HAS BEEN DESIGNED TO PROVIDE SAFE AND EFFICIENT SERVICE IF OPERATED AND MAINTAINED CORRECTLY.

MANY ACCIDENTS OCCUR THROUGH FAILURE TO ADHERE TO FUNDAMENTAL SAFETY PROCEDURES.

**Stephill Generators Ltd
Wallis close
Park Farm South
Wellingborough
Northants
NN8 6AG**

Issue 4

07/07/21

Contents

		Page
1	SPECIFICATION	1
2	GENERAL SAFETY	1
2.1	Warning signs	1
2.2	Safety hazards	1
3	POTENTIAL HAZARDS	1
3.1	Auxiliary power	1
3.2	Operating environment	1
4	SAFETY CONSIDERATIONS	1
4.1	General	1
4.2	Fuel	2
4.3	Lubricating oil	2
4.4	Safe lifting	2
4.5	Earth connection	2
4.6	Fumes	2
4.7	Noise	2
4.8	Battery acid	2
4.9	Fire	2
4.10	Hot parts	2
5	MAST DEPLOYMENT	3-4
6	OPERATING INSTRUCTIONS	4
6.1	Pre-start checks	4
6.2	Warning	4
6.3	Fuel system bleeding	4
6.4	Control panel	4
6.5	Long term storage	4
7.0	DEEP SEA 3110 OPERATING INSTRUCTIONS	5
7.1	Description of controls	5
7.2	Starting the engine	5
7.3	Starting sequence	5
7.4	Engine running	5
7.5	Stopping the engine	5
7.6	Automatic operation	5
7.7	Waiting in auto mode	5
7.8	Viewing the instruments	6
7.9	Fault icons & fault finding	6-8
8.0	SERVICE AND MAINTENANCE	7-8
8.1	Engine service	8
8.2	Alternator service	8
9.0	ALTERNATOR SPARES	9
10	YANMAR CONSUMABLE SPARES	9
11	SPARES GENERAL	9-10
12	WARRANTY	10
13	SLT5000 CANOPY EXPLODED VIEW	11
13.1	SLT5000 BASE EXPLODED VIEW	12
14	MAST EXPLODED VIEWS	13
14.1	120MM SECTION EXPLODED VIEW	13
14.2	MAST STOP EXPLODED VIEW	14
14.3	100MM SECTION EXPLODED VIEW	15
14.4	80 & 60MM SECTION EXPLODED VIEW	16
14.5	40MM SECTION & HEAD EXPLODED VIEW	17
14.6	MAST LEGS EXPLODED VIEW	18
14.7	FRONT AXLE EXPLODED VIEW	19
14.8	REAR AXLE EXPLODED VIEW	20
14.9	ROAD TRAILER EXPLODED VIEW	21
	DC WIRING DIAGRAM	22
	AC WIRING DIAGRAM	23

1 SPECIFICATION

GENERATOR

kVA	4.5
kW	3.6
LWA	96
dBA@7M	71
Alternator	Meccalte
Voltage	230v / 115v
Frequency	50HZ
Cos φ	0.8
Insulation class	F
Mechanical protection	IP23
Weight wet	400Kg
Length	1150mm
Width	1050mm
Height	2390mm
Fuel	34L
Autonomy 75% load	17
Autonomy 800W (Lights only)	29

ENGINE

Engine	Yanmar L70N
Oil capacity	1.65L
Combustion	Direct injection
Cooling	Air
Speed	3000rpm
Battery	

LIGHTING TOWER

Maximum height	5.2M
Maximum wind stability	80 km/h
Lamp power	4 x 200W
Lumens	100,000

DIMENSIONS

Maximum height	5.2M
Maximum wind stability	80 km/h
Weight wet	400Kg
Minimum dimension L x W x H mm	1150 x 1050 x 2390
Deployed dimension L x W x H mm	1660 x 1940 x 5400

2 GENERAL SAFETY

2.1 Warning signs

Warnings shown on the machine should be observed at all times. The warning signs should be checked for legibility and any that have become damaged should be replaced.

2.2 Safety hazards

It is important to keep the generator clean and well serviced, in particular keep all air vents / louvers clear of debris to prevent poor performance or possible overheating and permanent damage to the generator.

Keep well clear of moving parts on the generator at all times.

3 POTENTIAL HAZARDS

3.1 Auxiliary power

The electricity produced by an engine driven Generator is very similar to mains electricity and should be treated accordingly.

Do not remove covers and attempt to work on the Generator while the engine is running.

Check the rating and electrical safety of the load before connecting the Generator.

Equipment should never be connected that in total exceeds the specified rating of the Generator.

Installation of the generator as a standby or secondary power source should only be undertaken

by a fully qualified electrician using the appropriate means of isolation from the mains supply.

Installation must comply with all applicable laws and electrical codes.

3.2 Operating Environment

The Generator should always be operated on level ground.

A temperature range between -10°C and +40°C are the normal limits of operation. Operating outside the range will require additional modifications.

The standard reference condition for relative humidity is 30%. Above this value the rated power must be reduced.

The standard reference condition for total barometric pressure is 1 bar. This corresponds to an altitude of approximately 100m. Above 100m the rated power must be reduced.

This generator must not be used in a flammable environment.

Operation of the machine in a saline environment will require additional corrosion protection.

4 SAFETY CONSIDERATIONS

4.1 General

All Stepill Generators comply with all the current EEC directives:

4.2 Fuel

Fuels and lubricants are a potential source of fire. Lubricants in particular used engine oil, are potentially carcinogenic. Direct contact should always be avoided by wearing suitable rubber gloves when handling them. Be careful not to spill fuel, clean up any spillages. Inhalation or swallowing of Diesel should be avoided. If in doubt seek medical advice. All other forms of contact are irritant and therefore should also be avoided. If skin contact is made wash with soap and water.

4.3 Lubricating Oil

Prolonged contact with the oil may give rise to irritation and dermatitis. Used oil should not be allowed to contact the skin. If this does occur, wash off quickly with a proprietary hand cleanser.

4.4 Safe Lifting

Where mechanical assistance is used in lifting the generator ensure the lifting eye is used, and that all components used to lift the generator are within their Safe Working Load (SWL). The integral lifting beam and associated lifting eye on the generator should be regularly checked for signs of damage or gross corrosion. All Nuts and Bolts associated with the lifting beam should be regularly checked for tightness and corrosion. Lifting equipment should not be attached directly to the Engine/Alternator except for lifting of Engine/Alternator only.

4.5 Earth connection

All Stephill products are fitted with an earth stud on the control panel this can be connected to an earthing system or spike. Any earth spike required is dependant on the local conditions of use. The size is determined by reference to current IEE regulations or to a competent electrician.

4.6 Fumes

Make sure that the Generator is at least 2 metres away from any building during operation. Operate in a well ventilated unconfined area, so that fumes can be properly dispersed. Silencer outlet should be facing an open area to prevent fumes being recirculated. There is the danger of asphyxiation due to exhaust gases. Inhalation of poisonous exhaust fumes can lead to serious injury or death. The generator must not be used in a poorly ventilated or enclosed area.

4.7 Noise

Ear protection may be required depending on the combined noise level of the Generator, auxiliary load and the operator's distance from it and the length of exposure. (Noise at Work Regulations 1989)

4.8 Battery Acid

This is corrosive and irritant by all forms of exposure. Direct contact should always be avoided by wearing suitable rubber gloves, some form of eye protection should also be used. If skin contact is made wash with clean water.

4.9 Fire

Ensure that suitable fire extinguishers (AFFF or CO₂) are kept within proximity to the generator. Do not cover, enclose, or obstruct the airflow to the generator during or shortly after use, due to fire hazard or damage to the generator from overheating. Allow the generator to cool after use before storing away. Keep all inflammable objects clear of the Generator.

4.10 Hot parts

There is the danger of burns as parts of the generator will become very hot during use. No part of the engine, alternator or exhaust must be touched during or shortly after operation. Do not operate the generator unless all guards are in place.

5 MAST DEPLOYMENT

5.1 Pre Deployment checks

Before operating the lighting tower make sure all safety regulations and instructions have been followed. Do not deploy the mast unless the machine is standing on a level surface and the stabilizers have been fully adjusted.

- Surface on which lighting tower is placed is flat and has no obstructions.
- Wind speed does not exceed 80Kmph
- Do not deploy the mast in the vicinity of overhead power cables: DANGER OF ELECTROCUTION.
- Ropes and winch are not damaged
- Mast is mechanically sound with no loose parts
- Make sure that nobody is standing too close to the lighting tower when the mast is being deployed.

5.2 Deployment

5.2.1 Lock brake as shown



5.2.2 Deploy legs as shown



5.2.3 Place pin through turnbuckle and tighten

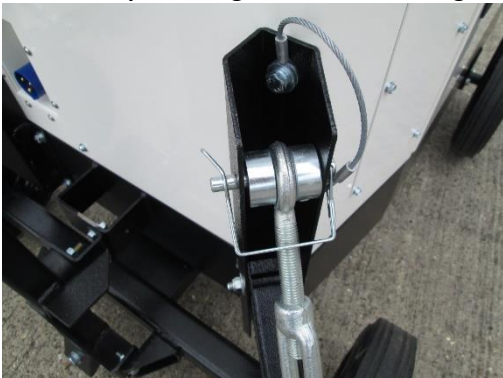

5.2.4 Release catch and drop handle

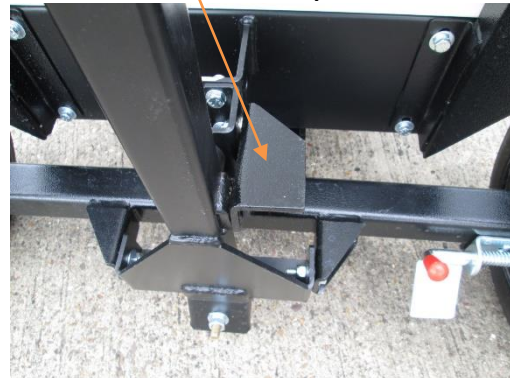

5.2.5 Position lamp heads as required, release plunger pin to change angle of head.



5.2.6 Check legs are secure and winch mast until you see the red line on the 2nd section. The mast is equipped with a safety stop to prevent the mast being raised too high.

WARNING

The mast should not go beyond the red line and should **not be locked against the safety stop.**



6 OPERATING INSTRUCTIONS

6.1 Pre-start checks

Before starting the generator please read the Yanmar engine owners manual.

Check Fuel & Oil level before attempting to start.

The generator is equipped with a low fuel level switch which will shutdown the engine and prevent it from starting, if the fuel level is low.

The engine is equipped with an oil and temperature switch and will shutdown for low oil pressure and high engine temperature.

6.2 Warning

Do not operate the changeover switch with load connected.

Always switch load off before disconnecting plugs.

To switch power off at the Generator always use the circuit breaker.

6.3 Fuel system bleeding

A self-bleeding system is fitted to the engine, the engine should not need bleeding unless maintenance has been carried out. Press the fuel pump prime button to bleed the system.

6.4 Control panel

LED Lamps will operate automatically on either voltage.

Before connecting plugs into the generator ensure the load is turned off. If this is not possible turn the circuit breaker to the off position.

Turn the voltage selector switch to the required voltage.

Selector switch can be operated with LED lamps lit.

Connect the plug/plugs into the generator.

Switch on the load / Circuit breaker.

Always turn the load off before stopping generator.

6.5 Long term storage

For storage or long periods of inactivity, Stephill Generators recommend the following:

Generators should be stored with oil filled to the correct capacity; Storage periods of 18 months and over may require special lubricants and treatments. If so please seek further advice from the engine manufacturer.

Before the generator is used after long term storage, all fuels and oils should be replaced.

Generator mounts, pipes and hoses should be checked to ensure that they are un-perished following extended periods of storage.

The generator should be stored in a clean dry area, ideally having a reasonable constant ambient temperature, and ideally not below freezing.

7 DEEP SEA 3110 OPERATING INSTRUCTIONS

7.1 Description of controls

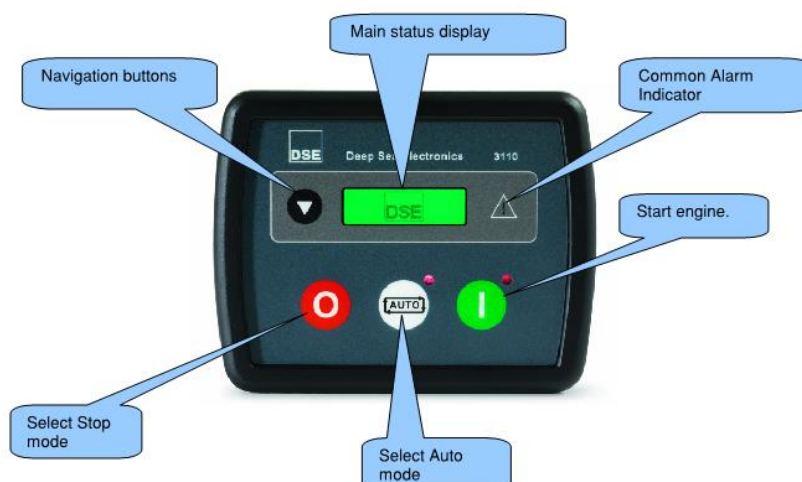

7.2 Starting the engine

To begin the starting sequence, press the  button.

The  icon is displayed to indicate Manual mode and the manual LED flashes.

The  button must be pressed once more to begin the start sequence.

7.3 Starting sequence

If a start request is present, the fuel relay is energised and the engine will be cranked. If the engine fails to fire during this cranking attempt then the starter motor is disengaged for the *crank rest* duration after which the next start attempt is made. Should this sequence continue beyond 3 attempts, the start sequence will be terminated and the display shows **Fail to Start**.

When the engine fires, the starter motor is disengaged. Speed detection is factory configured to be derived from the main alternator output frequency.

After the starter motor has disengaged, the *Safety On* timer activates (10 Sec), allowing Oil Pressure, High Engine Temperature, Under-speed, Charge Fail and any delayed Auxiliary fault inputs to stabilise without triggering the fault.

7.4 Engine running

Once the engine is running and all starting timers have expired, the animated icon is displayed. If all start requests are removed, the *stopping sequence* will begin.



7.5 Stopping the engine

In manual mode the set will continue to run until either:

The *stop button*  is pressed – The set will immediately stop

The *auto button*  is pressed. The set will observe all auto mode start requests and stopping timers before beginning the *Auto mode stopping sequence*.

7.6 Automatic operation

Activate auto mode by pressing the  pushbutton. The  icon is displayed to indicate Auto Mode operation if no alarms are present.

Auto mode will allow the generator to operate fully automatically, starting and stopping as required with no user intervention.

7.7 Waiting in auto mode

If a starting request is made, the starting sequence will begin.

Starting requests can be from the following sources:

Activation of an auxiliary input that has been configured to *remote start*.

7.8 Viewing the instruments

It is possible to scroll to display the different pages of information by repeatedly operating the scroll button 

Once selected the page will remain on the LCD display until the user selects a different page or after an extended period of inactivity, the module will revert to the status display.





When scrolling manually, the display will automatically return to the Status page if no buttons are pressed for the duration of the configurable *LCD Page Timer*.

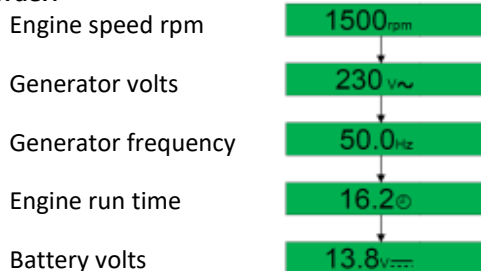



If an alarm becomes active while viewing the status page, the display shows the Alarms page to draw the operator's attention to the alarm condition.

Page order:-



7.9 Fault icons & fault finding

Fault Description	Checks and Tests
Deep Sea unit is inoperative and will not respond. No power at the unit.	<ul style="list-style-type: none"> • Check the battery and wiring to the unit. • Check the DC supply (battery). • Check the DC reset button/fuse • Check all plugs on the back of the Deep Sea 3110. • Check battery isolator switch is on. • Check for loose wires on battery isolator.
Deep Sea unit shuts down	<ul style="list-style-type: none"> • Check DC supply voltage is not above 16v or below 9v. • Check the operating temperature is not above 70°C. • Check the DC reset button/fuse.
Emergency Stop 	<ul style="list-style-type: none"> • Check emergency stop has been activated. • Check emergency stop switch is functioning correctly. • Check No.12 wiring is <u>not</u> open circuit. • Check all plugs on the back of the Deep Sea 3110.
Low Oil Pressure Fault occurs after engine has fired. 	<ul style="list-style-type: none"> • Check oil level and fill to correct level if necessary. • Check oil pressure switch/sensor-(remove switch, clean and replace). <u>An oil & filter change would be advisable.</u> • Check for loose wires on the oil switch & DC loom plug. • Check all plugs on the back of the Deep Sea 3110. • Replace oil switch/sender.
High Engine Temperature Fault occurs after engine has fired. 	<ul style="list-style-type: none"> • Check engine temperature. • Check if the electric fan operates. (if applicable). • Check switch/sensor wiring & DC loom plug. • Check switch polarity is correct. (Ref. diagram) • Check for loose wires on the temperature switch • Check condition of the fan/fan belt. (replace if necessary). • Check generator air inlets and outlets are not obstructed. • Check the radiator fins are not obstructed/dirty. • Check all plugs on the back of the Deep Sea 3110. • Check engine thermostat is operational. (if applicable).
Fail to Start Is activated after three attempts to start. 	Engine <u>not</u> starting/running <ul style="list-style-type: none"> • Check battery DC supply. • Check fuel level and fuel condition. • Is the engine due a service? Has the generator run out of fuel recently? Check fuel filters and replace.

Fault description	Checks and Tests
<p>Fail to Start Is activated after three attempts to start.</p> 	<ul style="list-style-type: none"> • Check fuel solenoid/pump is operational and wiring. • Check all fuel hose(s) and clips. • Check that fuel is being returned from the injectors into the fuel tank. (if applicable). • Check all plugs on the back of the Deep Sea 3110. • Check battery supply is present on the fuel output of the module. (Ref. diagram). • Check fuel relay operation. • Check all negative/ground connections. <p>Engine starting/running but stopping</p> <ul style="list-style-type: none"> • Check AC supply into the Deep Sea module (Brown + Blue), should be approximately 115V or 230V AC. • Check AC reset button. • Check AC output from the generator, a faulty main alternator could display "Fail to start" icon. • While the generator is at standstill and the module display is on, using the  button check that the Deep Sea module will display an AC voltage, frequency (Hz) and rpm screen. If none are shown, see <i>resetting procedure at the bottom of this guide.</i>
<p>Fail to stop</p> 	<ul style="list-style-type: none"> • "Fail to stop" could indicate a faulty oil pressure switch/sender. See "Low oil pressure" checks and tests. • Check wiring and engine loom plug. • Check all plugs on the back of the Deep Sea 3110. • Check low oil pressure switch is operating correctly. • Replace oil switch/sender. • Check fuel relay operation. (Ref. diagram).
<p>Low Hz/Frequency and Low Voltage shutdown</p> 	<ul style="list-style-type: none"> • Check AC reset button. • Check the AC output from the generator ,no output could indicate a fault with the main alternator. • Check fuse on AVR or capacitor. (main alternator) • Check AC supply into the Deep Sea module (Brown + Blue). should be approximately 115V or 230V AC. • Check engine/rotational speed is around 52.5 Hz at <u>no-load</u>. • Is the engine due a service, check fuel filters and replace. • Is the engine running correctly, check fuel condition and fuel system, pump, pipes and clips etc.
<p>High Hz/Frequency and High Voltage Shutdown</p> 	<ul style="list-style-type: none"> • Check engine/rotational speed is 52.5 Hz at no-load. • Check AC supply into the Deep Sea module (Brown + Blue). should be approximately 115v or 230V AC. • Check the capacitor (if applicable). • Check the AVR and wiring (if applicable).
<p>Battery flat-not charging</p>	<ul style="list-style-type: none"> • Check for loose wires on charge alternator/dynamo. • Check AC volts out at the dynamo. (if applicable) • Check for loose wires on the DC plug/socket and Deep Sea 3110. • Check charge regulator wiring and replace if necessary. (if applicable) • Check continuity of all wires from charge alternator. (if applicable) • Check exciter DC voltage from the Deep Sea 3110 when running. • Check voltage at the battery while generator is running, voltage should be 13.4V – 15V DC. • Check/change the battery.

Fault description	Checks and Tests
Starter motor inoperative	<ul style="list-style-type: none"> • Check battery DC supply. • Check wiring to starter motor. • Check battery supply is present on the starter output of module when starting. • Check all plugs on the back of the Deep Sea 3110. • Check starter motor relay wiring and operation.
Fuel pump and/or fuel solenoid not operating	<p><u>Note:</u> On most Stephill Generators the fuel solenoid and fuel pump are on the same circuit.</p> <ul style="list-style-type: none"> • Check battery DC supply. • Check the DC loom fuses and wiring. • Check for loose wires on the fuel solenoid/pump and relay. • Check function of the fuel relay and that the relevant wiring operation. • Check voltage at the fuel solenoid and/or pump when requested. • Replace solenoid or pump if 12 volt DC present when requested. • Check emergency stop operation. • Check DC volts at the Deep Sea module for fuel relay output when requested.
Continuous starting of the generator when in Auto 	<ul style="list-style-type: none"> • Check that there is no signal present on the “Remote Start” input. • Check configured polarity is correct.
Generator fails to start on receipt of a remote start signal	<ul style="list-style-type: none"> • Check Start Delay timer has timed out. (Not configured on standard builds) • Check signal is on “Remote Start” input. • Check there is no fault icons on the Deep Sea 3110.

▲ NOTE:- The above fault finding is provided as a guide check-list only. For further information <http://www.deepseapl.com/>

8 SERVICE AND MAINTENANCE

IMPORTANT WARNING:

After any service on the generator, ensure that all piping and electrical cables are correctly routed and secured away from hot parts. Failure to observe this warning may result in damage to the piping and cables which could result in a fire.

**Do not service or work on the generator whilst the engine is running.
Always disconnect battery prior to working on engine or alternator.**

8.1 Engine service

Service the engine strictly in accordance with the instructions given in the relevant operator manual / handbook. An approved specialist must carry out any maintenance. Any spare parts required should be of genuine manufacturer’s origin. Note: failure to adhere to manufacturer’s recommended service schedules may invalidate the warranty. Please consult engine operator’s manual for full service intervals.

8.2 Alternator service

Brushless alternators employed on Stephill Generators are maintenance free. Service must be carried out by competent qualified personnel strictly in accordance with the instructions given in the handbook. Any spare parts required should be of genuine manufacturer’s origin.

9 ALTERNATOR SPARES

Part No	Alternator	Description
9910356205	Meccalte S16W-130	Diode
037-0016	Meccalte S16W-130	Capacitor - 25µf

10 YANMAR CONSUMABLE SPARES

Part No	Description
029-0016	Air filter
029-0032	Oil filter

11 SPARES GENERAL

Part No	Description	Qty
029-0005	ENGINE L70N	1
018-0079	ALTERNATOR 5kVA S16W/130	1
028-1172	WIRE ROPE BOSS	4
028-1145	SLT5000 LIGHT TOWER LAMP SPACER	4
058-1001	LED LAMP 200W	4
058-1038	4 WAY LOOM LED LAMPS	1
058-1017	BEARING 618042RS-ZEN SLT5000	4
058-1031	SLT5000 WINCH	1
058-1035	5mm x 1750mm GALVANISED WIRE ROPE (WINCH)	1
058-1036	5mm x 1100mm GALVANISED WIRE ROPE	3
023-1015	RAIN CAP 9000700 37mm/39mm	1
023-1098	FIBREGLASS SLEEVE SILVER	1M
028-1117	SLT5000 MANIFOLD PIPE	1
028-1118	SLT5000 TAIL PIPE	1
028-1119	SLT5000 SILENCER	1
036-0050	RESET BUTTON 20 AMP JX7420	1
045-0006	FUEL PUMP PRIME	1
045-0018	EMERGENCY STOP BUTTON	1
045-0032	CONTACT BLOCK NORMALLY CLOSED	1
045-0061	DEEPSEA MODULE 3110-01	1
045-0062	GASKET FOR DEEPSEA 3110 MODULE	1
055-0010	GAUGE FUEL	1
056-0002	RELAY 4 PIN SR/1A 12VDC	2
036-0002	MCB GTEC 10 AMP 1 POLE	1
036-0006	MCB GTEC 16 AMP 2 POLE	1
036-0049	RESET BUTTON 16 AMP JX7416	3
036-0056	DUST COVER IP23 RESET BUTTON	1
036-0079	2AMP FUSE	1
036-0116	MCB GTEC 6 AMP 1 POLE GTEC1C06	1
043-0001	SWITCH TOGGLE CHANGE OVER	1
043-0014	SWITCH TOGGLE IP23 COVER	1
044-0001	SOCKET 115V 16A	1
044-0002	SOCKET 230V 16A	1
044-0003	SOCKET 115V 32A	1
056-0013	RELAY- 230V AC COIL FINDER 3PDT	1
058-1040	WATERPROOF 3 POLE SOCKET	1
014-1000	HINGE DOOR M5	2
014-1004	HANDLE FLUSH	1
016-1050	EMERGENCY STOP HOUSING	1
016-1081	DOOR SHAPED WEATHERPROOF P HANDLE	1
022-0614	FAN COWL	1
022-1035	FAN	1

Part No	Description	Qty
022-1036	FAN LOCKING RING	1
023-0257	STRIKE / CATCH SSD K RANGE 9/00406	1
023-1000	HINGE M8	4
023-1002	RUBBER WINDOW SEAL	1M
023-1003	RUBBER WINDOWLOCKING STRIP	1M
026-2031	TEMP SENDER 120 DEGREE	1
027-0053	M8 WAISTED MOUNT ALTERNATOR	2
027-0054	M8 MOUNT ENGINE	2
028-1160	SLT5000 POLYCARBONATE DOOR GLASS	1
028-1162	SLT5000 IMPELLAR BOSS	1
054-0009	BATTERY 12N24-3	1
058-3000	AIR HOSE SUPER FLEX 38mm	1M
048-0008	FILLER CAP	1
045-0004	KEY (FT105)	1
058-1030	FUEL SENDER	1

12 WARRANTY

This generator supplied by STEPHILL GENERATORS LTD carries a warranty of 12 months from date of despatch or 2000 Hours.

During the warranty period, should the plant fail due to faulty design, materials or workmanship by STEPHILL GENERATORS LTD or its sub-contractors, we undertake to rectify the fault.

STEPHILL GENERATORS LTD will accept no responsibility whatsoever for equipment that has failed due to;

- Operation with incorrect fuel, lubricating oil.
- Improper repair or use of parts not supplied by STEPHILL GENERATORS LTD.
- Lack of, or incorrect maintenance.
- Fair wear and tear, misuse, negligence, accidental damage, improper storage, incorrect starting / warm-up / run-in or shutdown.

No warranty claim will be considered by STEPHILL GENERATORS LTD unless any defective parts are available for inspection by us, or our nominees, to determine the reason or cause of failure, and STEPHILL GENERATORS LTD is given the option of repair or replacement.

STEPHILL GENERATORS LTD are not responsible for incidental or consequential damages, downtime, or other costs due to warrantable failure, and unauthorised alterations made to any product supplied by STEPHILL GENERATORS LTD.

13 CANOPY EXPLODED VIEW

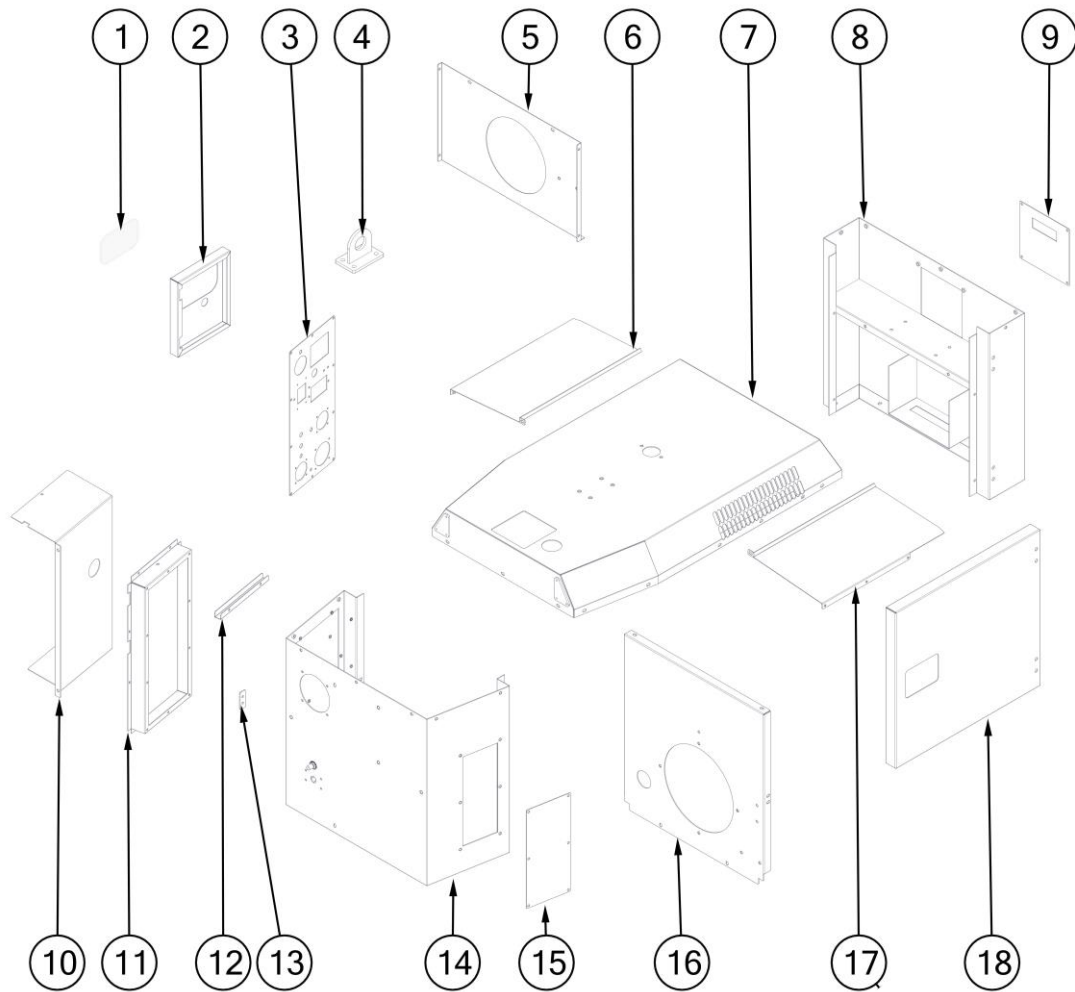

Item	Part Number	Description	Qty
1	028-1160	SLT5000 POLYCARBONATE WINDOW	1
2	028-1115	SLT5000 CONTROL PANEL DOOR	1
3	028-1116	SLT5000 CONTROL PANEL DUAL VOLTAGE	1
4	028-1105	SLT5000 LIFTING EYE	1
5	028-1109	SLT5000 ENGINE BULKHEAD PLATE	1
6	028-1107	SLT5000 ROOF DUCT NON SERVICE SIDE	1
7	028-1104	SLT5000 ROOF	1
8	028-1110	SLT5000 ENGINE END PANEL	1
9	028-1168	SLT5000 AIR CLEANER PLATE	1
10	028-1112	SLT5000 CONTROL PANEL COVER	1
11	028-1113	SLT5000 CONTROL PANEL HOUSING	1
12	028-1165	SLT5000 CONTROL PANEL GUTTER	1
13	028-1176	SLT5000 DOOR SPACER	2
14	028-1114	SLT5000 ALTERNATOR END PANEL	1
15	028-1151	SLT5000 INSPECTION DOOR	1
16	028-1111	SLT5000 ALTERNATOR BULKHEAD PLATE	1
17	028-1106	SLT5000 ROOF DUCT SERVICE SIDE	1
18	028-1108	SLT5000 DOOR	2

13.1 BASE EXPLODED VIEW

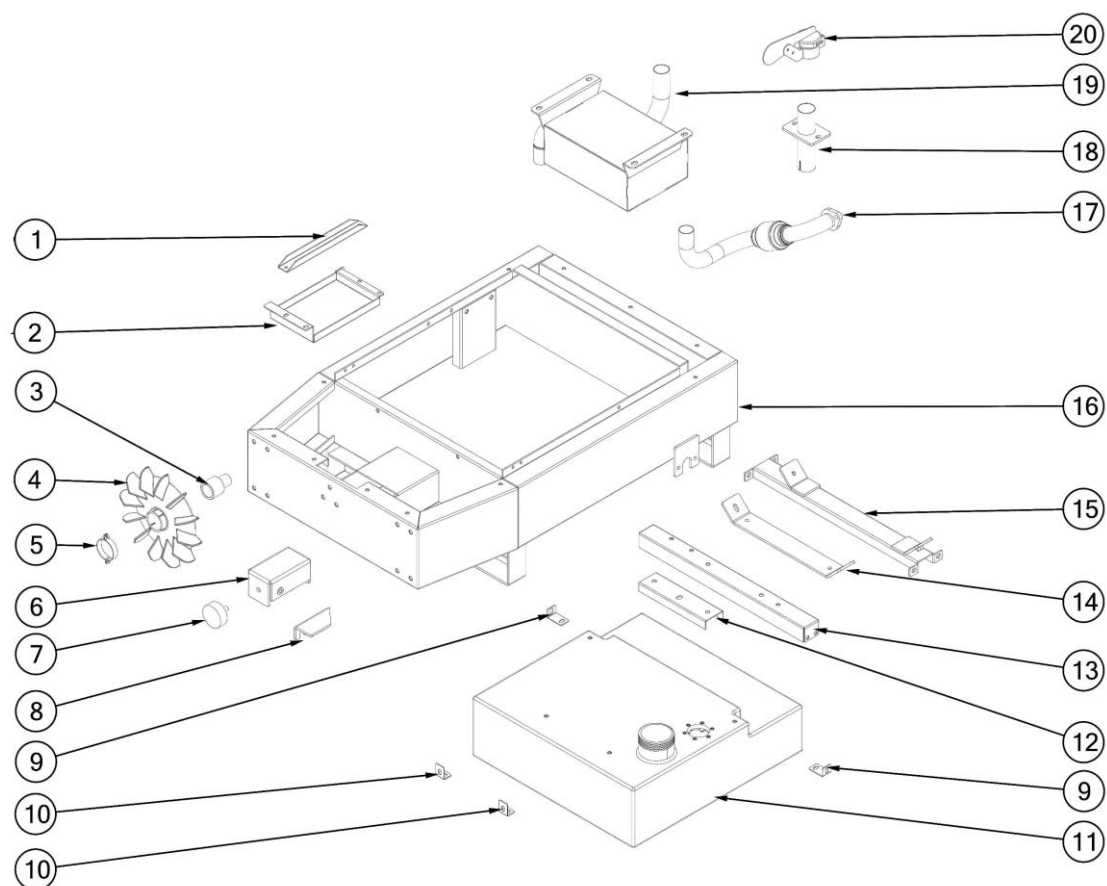

Item	Part Number	Description	Qty
1	028-1123	SLT5000 BATTERY BRACKET	1
2	028-1122	SLT5000 BATTERY TRAY	1
3	028-1162	SLT5000 IMPELLER BOSS	1
4	022-1035	FAN	1
5	022-1036	FAN LOCK RING	1
6	028-1120	SLT5000 HANDLE U BRACKET	1
7	009-0130	M10 RUBBER FOOT	1
8	028-1155	SLT5000 HANDLE CATCH	1
9	028-1121	SLT5000 FUEL TANK BRACKET LARGE	2
10	028-1103	SLT5000 FUEL TANK BRACKET SMALL	2
11	028-1146	SLT5000 FUEL TANK	1
12	028-1102	SLT5000 NSM ALTERNATOR BRACKET	1
13	028-1101	SLT5000 ALTERNATOR CHANNEL	1
14	028-1153	SLT5000 ENGINE BRACKET L70	1
15	028-1152	SLT5000 ENGINE CROSS MEMBER	1
16	028-1100	SLT5000 BASE	1
17	028-1117	SLT5000 MANIFOLD PIPE	1
18	028-1118	SLT5000 TAIL PIPE	1
19	028-1119	SLT5000 SILENCER	1
20	023-1015	RAIN CAP 37/39MM	1

14 MAST EXPLODED VIEWS

14.1 120MM SECTION EXPLODED VIEW

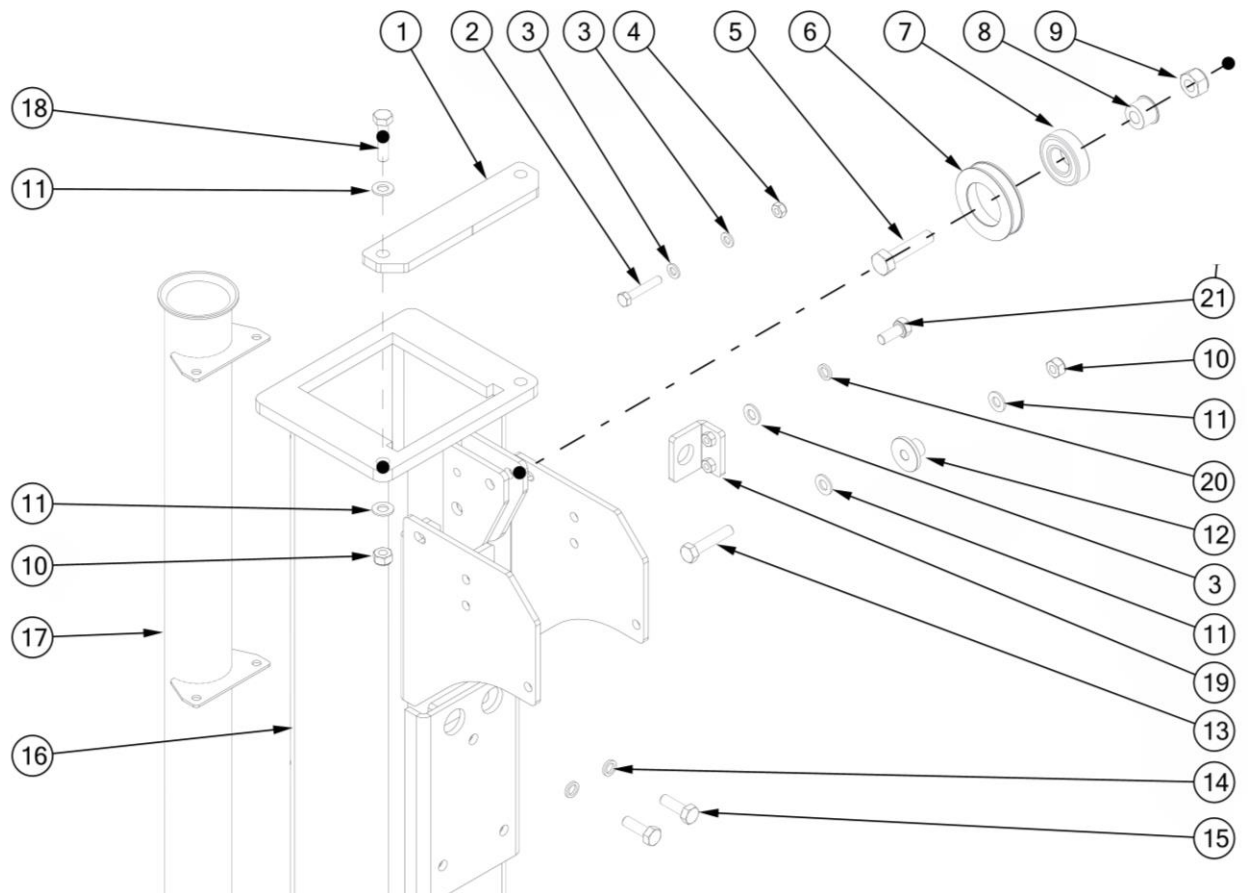

Item	Part Number	Description	Qty
1	028-1127	SLT5000 120MM GUIDE PLATE	2
2		M6 X 40 HEX BOLT BZP	1
3		M6 FLAT WASHER BZP	6
4		M6 NYLOK NUT BZP	1
5		M10 X 40 HEX BOLT BZP	1
6	028-1139	SLT5000 LIGHT TOWER PULLEY	1
7	058-1042	BEARING	1
8	028-1140	SLT5000 LIGHT TOWER BEARING SHAFT	1
9		M10 NYLOK NUT BZP	1
10		M8 NYLOK NUT BZP	2
11		M8 FLAT WASHER BZP	6
12	028-1172	SLT5000 WIRE ROPE BOSS	1
13		M8 X 40 HEX SET BZP	1
14		M8 SPRING WASHER BZP	2
15		M8 X 25 HEX SET BZP	2
16	028-1186	SLT5000 Mast 120MM	1
17	028-1134	SLT5000 CABLE TUBE	1
18		M8 X 35 HEX SET BZP	2
19	028-1191	SLT5000 MAST STOP GUIDE BRACKET	2
20		M6 SPRING WASHER BZP	4
21		M6 X 20 HEX BOLT BZP	4

14.2 MAST STOP EXPLODED VIEW

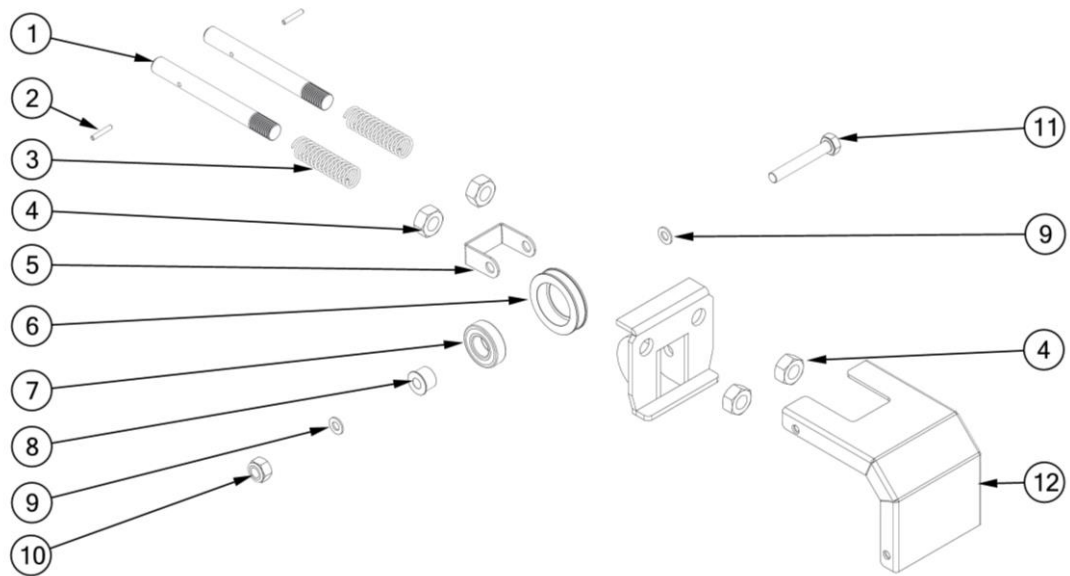

Item	Part Number	Description	Qty
1	028-1188	SLT5000 MAST STOP BOLT	2
2		M4 X 24 DOWEL PIN	2
3	028-1187	SLT5000 STOP BOLT SPRING	2
4		M16 HALF NUT	4
5	028-1192	SLT5000 MAST STOP PULLEY COVER	1
6	028-1139	SLT5000 LIGHT TOWER PULLEY	1
7	058-1042	BEARING	1
8	028-1140	SLT5000 LIGHT TOWER BEARING SHAFT	1
9		M10 FLAT WASHER	2
10		M10 NYLOK	1
11		M10 X 70 HEX BOLT BZP	1
12	028-1185	SLT5000 Mast stop cover	1

14.3 100MM SECTION EXPLODED VIEW

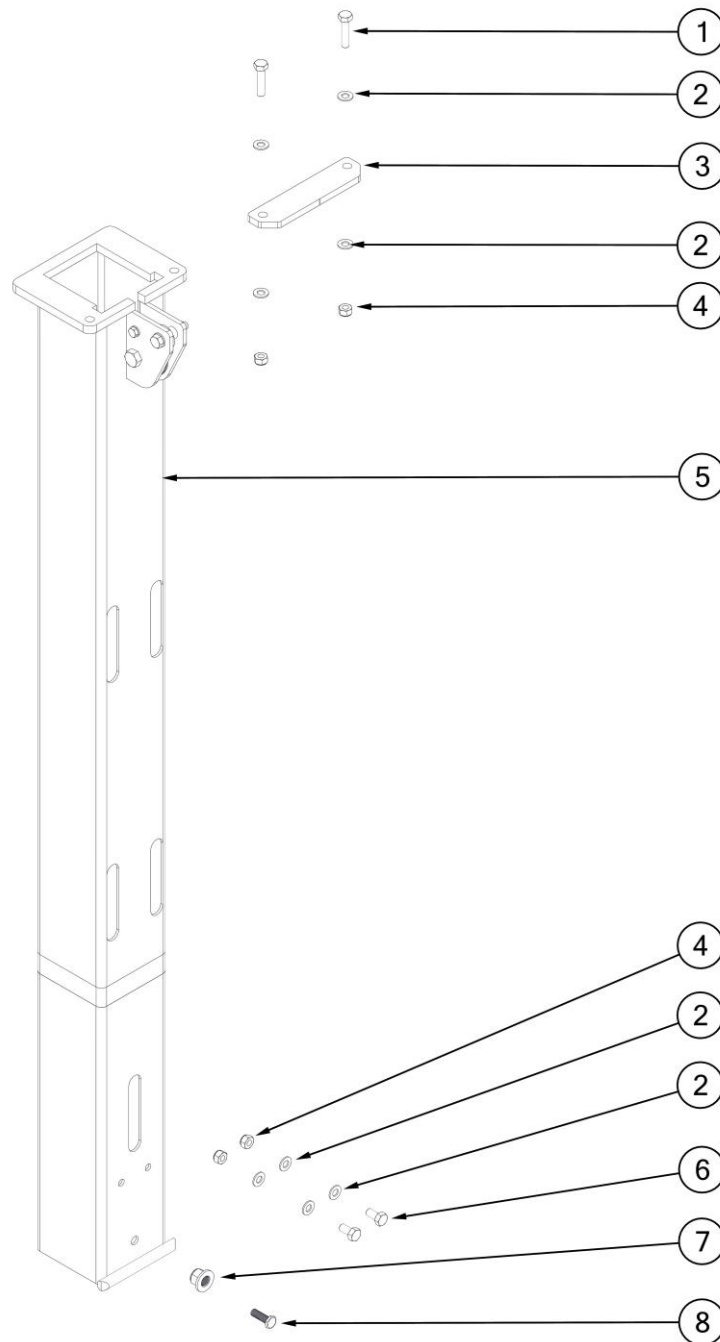

Note

For pulley assembly see Fig 14.1 Page 13

Item	Part Number	Description	Qty
1		M8 X 35 HEX BOLT BZP	2
2		M8 FLAT WASHER BZP	4
3	028-1126	SLT5000 100MM GUIDE PLATE	1
4		M8 NYLOK NUT BZP	4
5	028-1130	SLT5000 MAST 100MM	1
6		M8 X 20 HEX BOLT	2
7		M10 FLANGE NYLOK NUT BZP	1
8	028-1156	M10 BOLT BZP	1

14.4 80 & 60MM SECTION EXPLODED VIEW

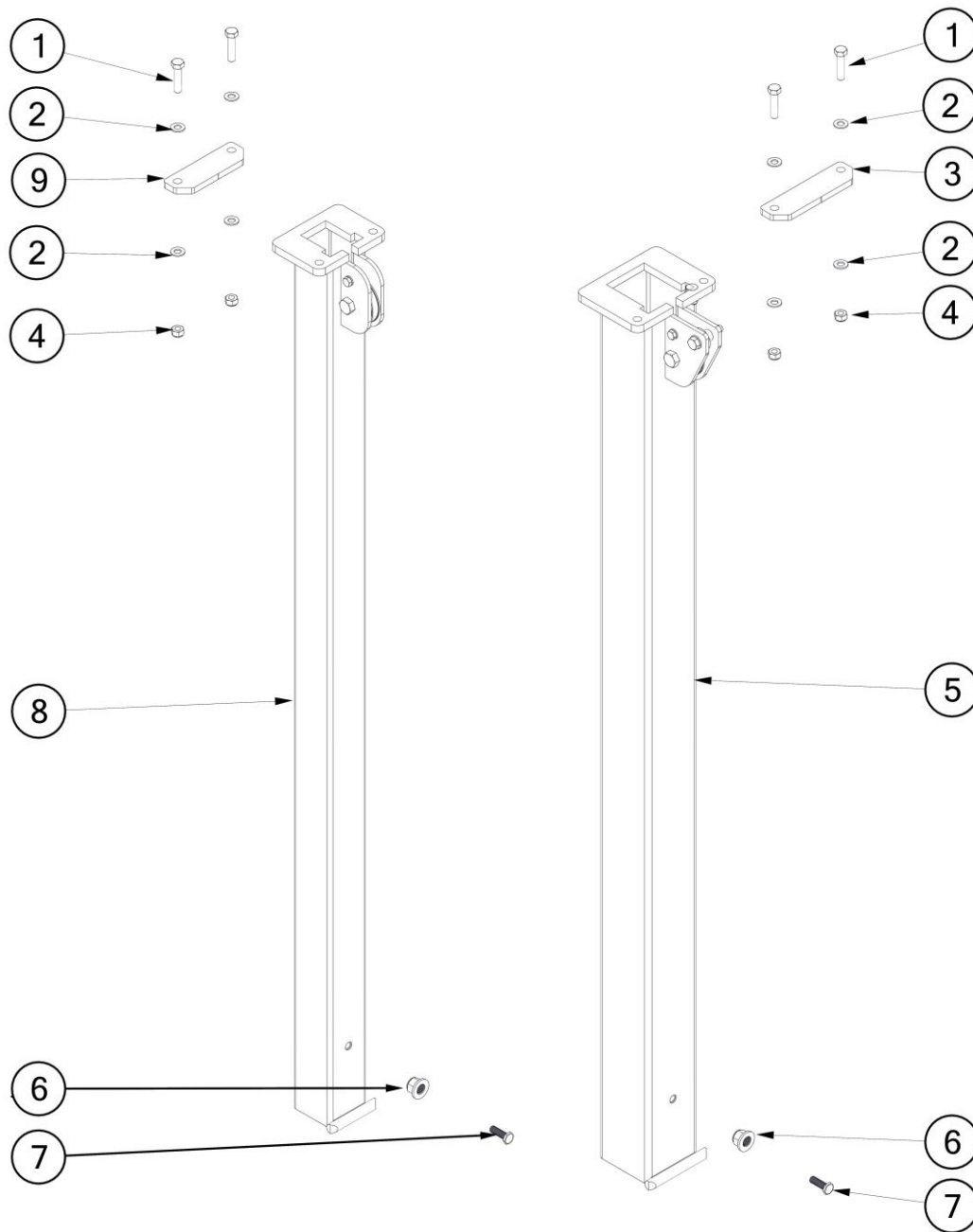

Note

For pulley assembly see Fig 14.1 Page 13

Item	Part Number	Description	Qty
1		M8 X 35 HEX BOLT BZP	4
2		M8 FLAT WASHER BZP	8
3	028-1125	SLT5000 80MM GUIDE PLATE	1
4		M8 NYLOK NUT BZP	8
5	028-1132	SLT5000 MAST 80MM	1
6		M10 FLANGE NYLOK NUT BZP	2
7	028-1156	M10 BOLT BZP	2
8	028-1133	SLT5000 MAST 60MM	1
9	028-1124	SLT5000 60MM GUIDE PLATE	1

14.5 40MM SECTION & HEAD EXPLODED VIEW

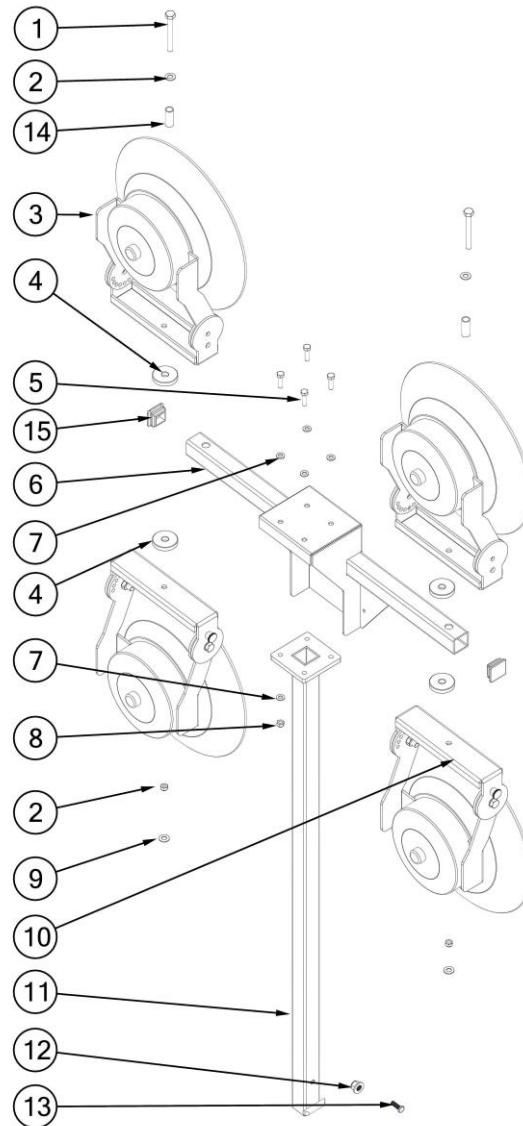

Note

For pulley assembly see Fig 14.1 Page 13

Item	Part Number	Description	Qty
1		M10 X 90 HEX BOLT BZP	2
2		M10 FLAT WASHER	2
3	058-1001	200W LED LAMP	4
4	028-1145	SLT5000 LIGHT TOWER LAMP SPACER	4
5		M8 X 25 HEX BOLT BZP	4
6	028-1128	SLT5000 LIGHT HEAD	1
7		M8 FLAT WASHER	8
8		M8 NYLOK	4
9		M10 FLAT WASHER	2
10	028-1190	SLT5000 LIGHT HEAD BRACKET	1
11	028-1131	SLT5000 MAST 40MM	1
12		M10 FLANGE NYLOK NUT BZP	2
13	028-1156	M10 BOLT BZP	1
14	028-1189	SLT5000 40MM SPACER	2

14.6 MAST LEGS EXPLODED VIEW

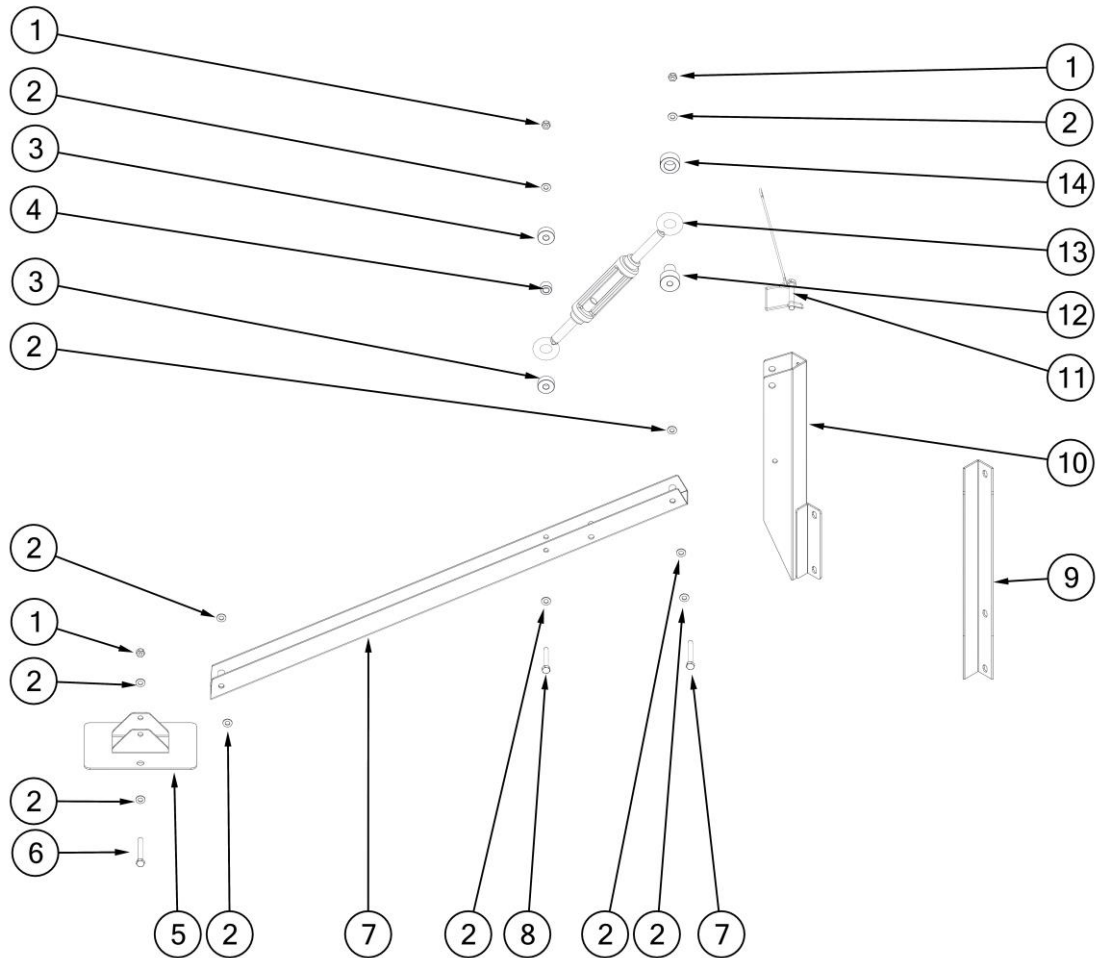

Item	Part Number	Description	Qty
1		M8 NYLOK	4
2		M8 FLAT WASHER	8
3	028-1142	SLT5000 LIGHT TOWER 12MM TURNBUCKLE SPACER	2
4	022-0847	TURNBUCKLE SPACER	1
5	028-1135	SLT5000 FOOT	2
6		M8 X 70 HEX BOLT BZP	2
7	028-1136	SLT5000 LEG	2
8		M8 X 65 HEX BOLT BZP	1
9	028-1138	SLT5000 RIGHT LEG BRACKET	1
10	028-1137	SLT5000 LEFT LEG BRACKET	1
11	058-1041	TAB LOCK PIN & WIRE ROPE	2
12	028-1144	SLT5000 47MM TURNBUCKLE SPACER	2
13	058-1012	M16 TURNBUCKLE	2
14	028-1143	SLT5000 LIGHT TOWER 17MM TURNBUCKLE SPACER	2

14.7 FRONT AXLE EXPLODED VIEW

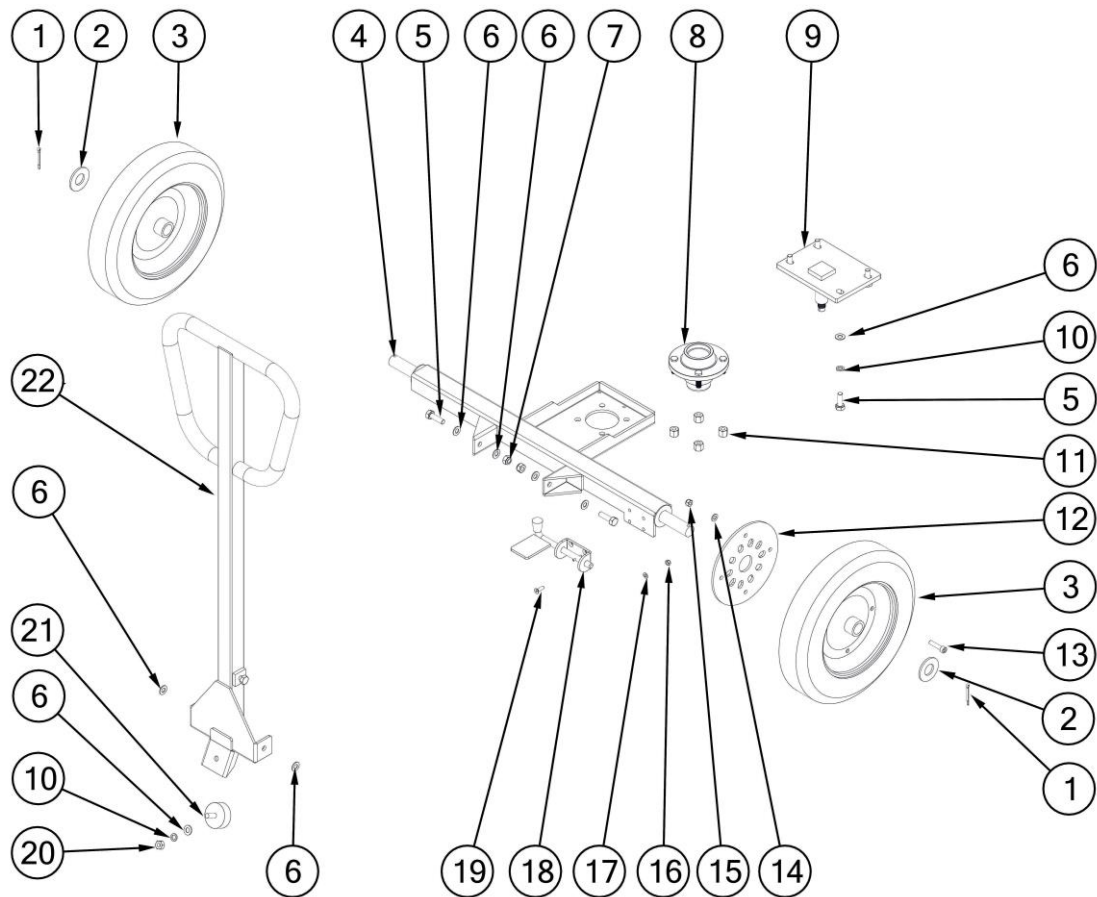

Item	Part Number	Description	Qty
1		M5 X 75 SPLIT PIN	2
2		WHEEL WASHER	2
3	027-0038	WHEEL	2
4	028-1149	SLT5000 FRONT AXLE	1
5		M10 X 35 HEX BOLT BZP	2
6		M10 FLAT WASHER BZP	11
7		M10 NYLOK BZP	2
8		STUB AXLE	1
9	028-1148	SLT5000 STUB AXLE PLATE	1
10		M10 SPRING WASHER	4
11		½" UNF WHEEL NUT	4
12		SLT5000 SPRING BOLT PLATE	1
13		M8 X 35 SOCKET CAP CREW BZP	4
14		M8 FLAT WASHER BZP	4
15		M8 NYLOK BZP	
16		M6 NYLOK BZP	
17		M6 FLAT WASHER BZP	
18	028-1157	SLT5000 BRAKE	1
19		M6 X 20 CSK BZP	4
20		M10 NUT BZP	1
21	009-0130	M10 RUBBER FOOT	1
22	028-1154	SLT5000 HANDLE	1

14.8 REAR AXLE EXPLODED VIEW

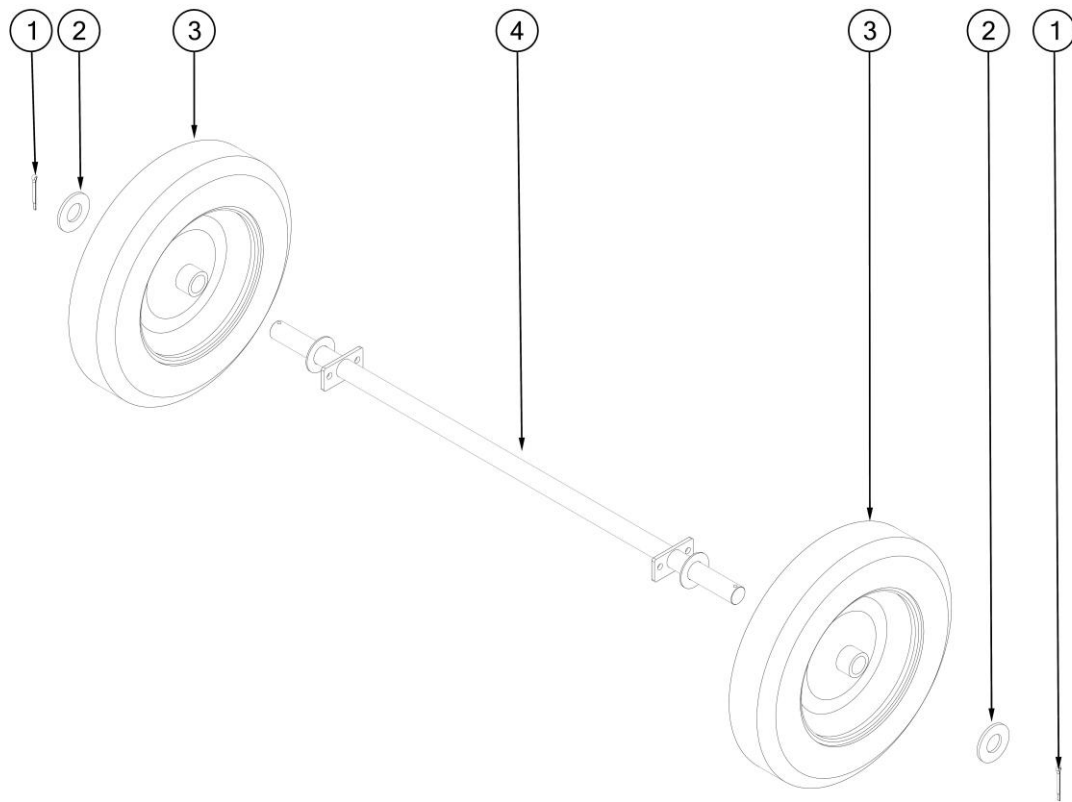

Item	Part Number	Description	Qty
1		M5 X 75 SPLIT PIN	2
2		WHEEL WASHER	2
3	027-0038	WHEEL	2
4	028-1147	REAR AXLE	1

14.9 ROAD TRAILER EXPLODED VIEW

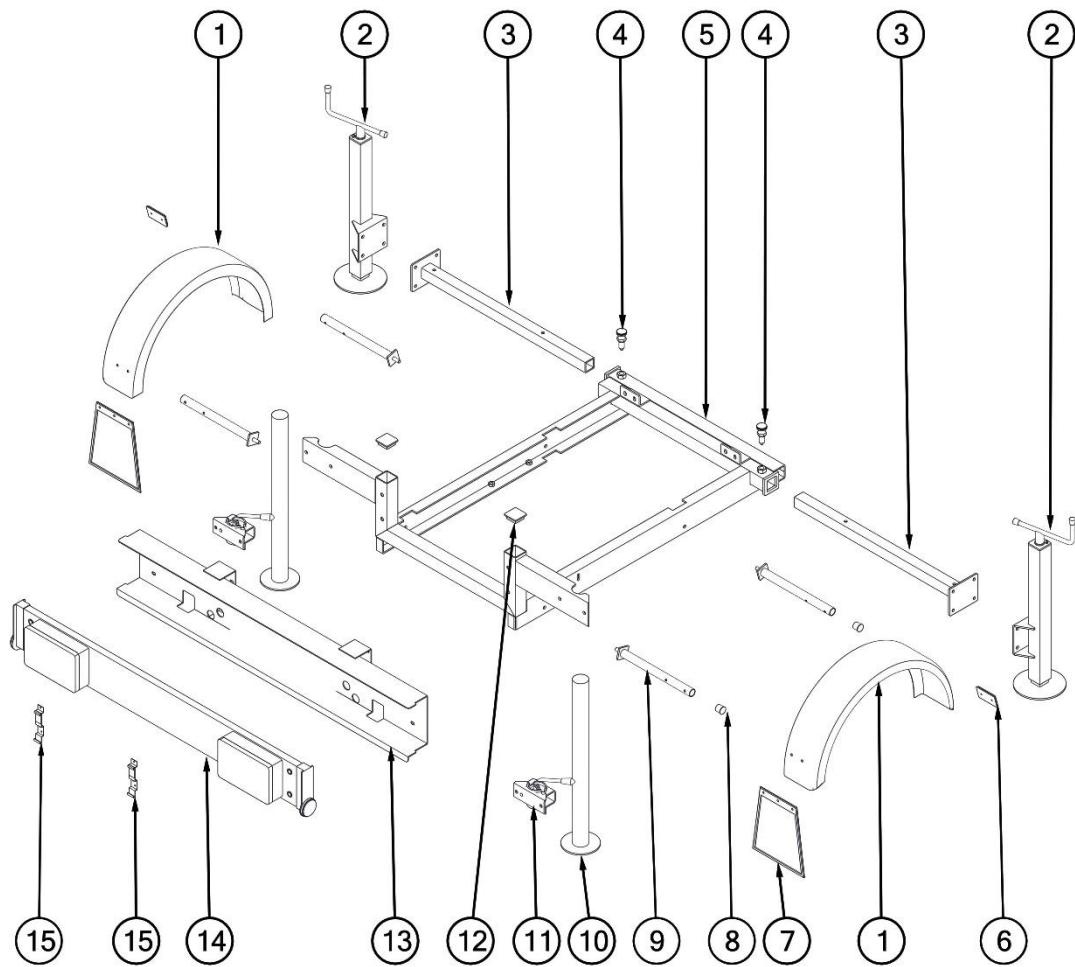

Item	Part Number	Description	Qty
1		MUDGUARD	2
2	028-1180	SLT5000 50MM ADJUSTABLE PROP STAND	2
3	028-1179	SLT5000 TRAILER OUTRIGGER	2
4	058-1043	INDEXING PLUNGER	2
5	028-1181	SLT5000 TRAILER MOUNTING FRAME	1
6	023-2022	RECTANGULAR CLEAR REFLECTOR	2
7	024-1036	MUD FLAP	2
8	023-1010	END BUNG CAP	4
9	028-1182	SLT5000 TRAILER MUDGUARD BRACKET	4
10	058-1052	48MM PROP STAND	2
11	058-1051	48MM CLAMP	2
12	058-1044	50 X 50 TUBE INSERT	2
13	024-0206	SSD10000 LIGHTING BOARD BRACKET	1
14	024-1035	XSG002 1230MM LIGHTING BOARD	1
15	023-1101	NUMBER PLATE HOLDER	2

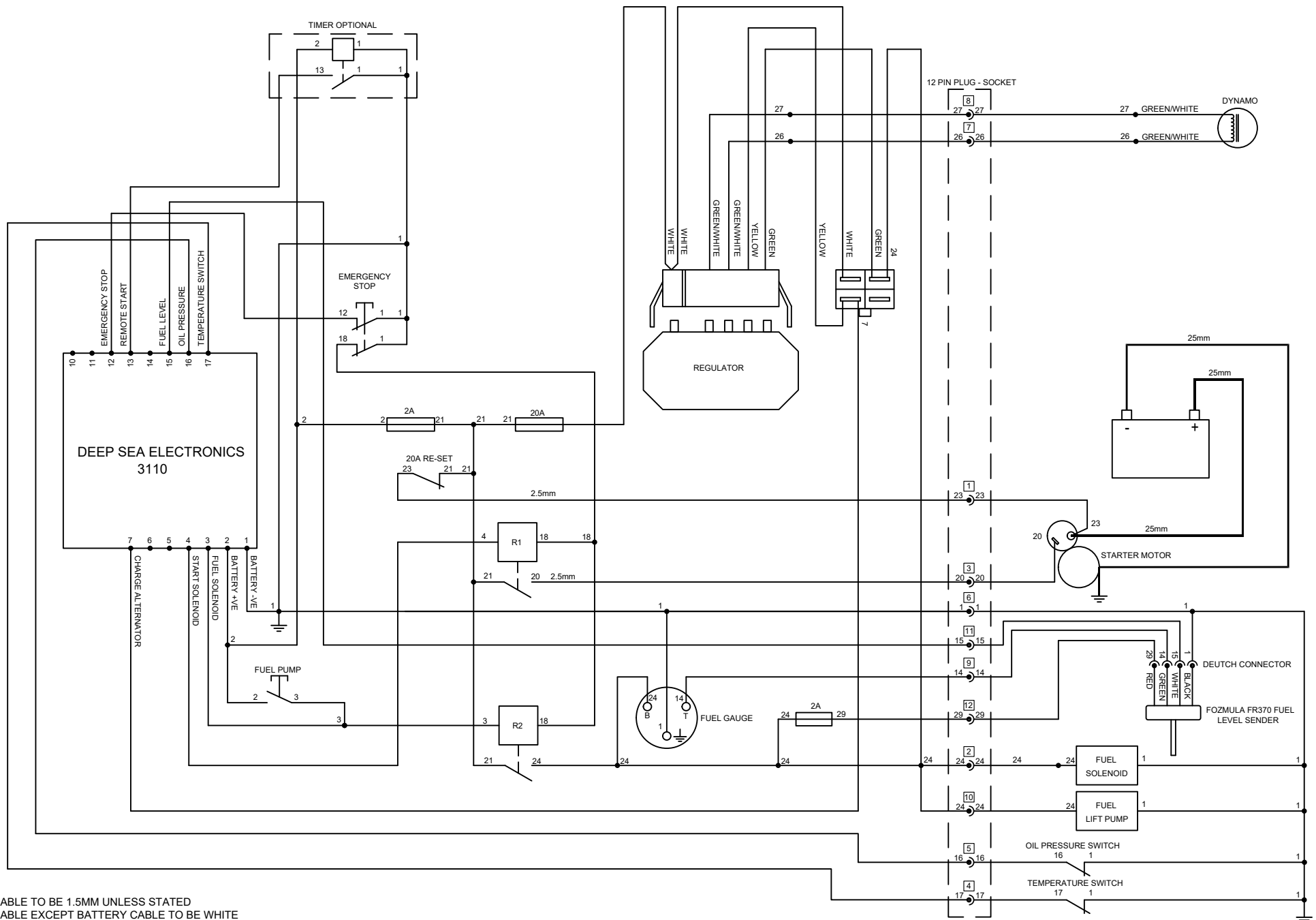

NOTE
 ALL CABLE TO BE 1.5MM UNLESS STATED
 ALL CABLE EXCEPT BATTERY CABLE TO BE WHITE

STEPHILL GENERATORS
 Phone 01933 677911
 Fax 01933 677916

Drawing Number
 SW11062
 Drawn
 R GOLDING

Description
 SLT5000 L70 Deep Sea 3110 Wiring with FR370 fuel gauge

Last Number Used
 31

Issue
 A

Date
 30-06-17

Revision
 New drawing

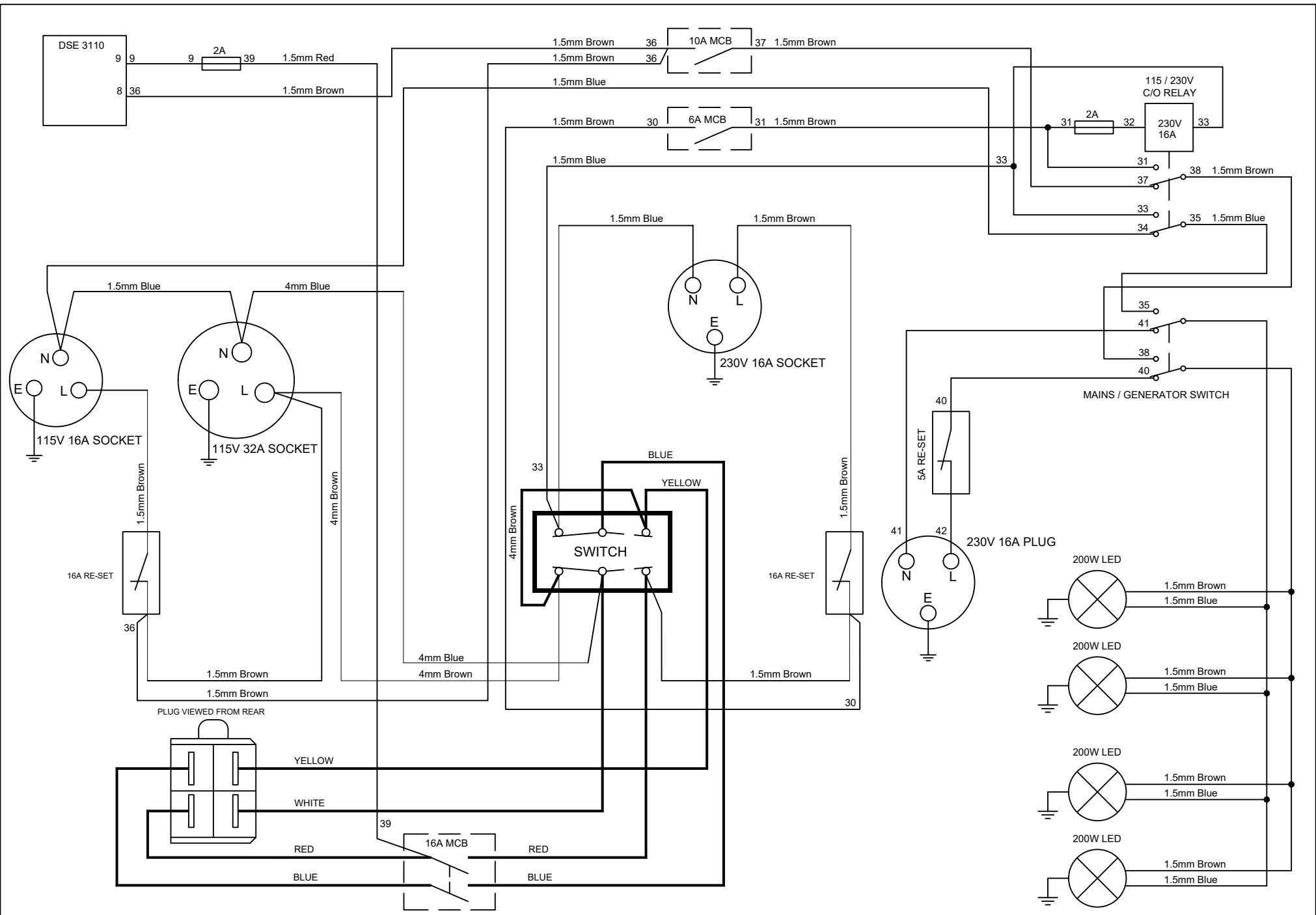

 STEPHILL GENERATORS Phone 01933 677911 Fax 01933 677916	Drawing Number SW12106	Description SLT5000 D/V 4 x 200W LED	Last Number Used 42	Issue A	Date 25/05/17	Revision New drawing
	Drawn R Golding					